



# VIP 110-24 Series Advanced Wireless Ethernet Bridge User Guide



February 2010 Rev: L



**Important**

You can obtain the latest customer documentation for this product by visiting our web site at <http://www.eionwireless.com/> . Click on [Support → Knowledge Centre](#). Updated information, including this manual, will be posted regularly on this site and can be downloaded via the Internet.



## **TABLE OF CONTENTS**

<b>1</b>	<b>IMPORTANT INFORMATION</b>	<b>1</b>
1.1	SAFETY CONSIDERATIONS	1
1.2	NOTICES	2
1.2.1	<i>Copyright Notice</i>	2
1.2.2	<i>Regulatory Notice</i>	2
1.2.3	<i>Other Notices</i>	3
1.2.4	<i>Warranty &amp; Repair</i>	3
1.2.5	<i>Customer Support Contacts</i>	3
1.2.6	<i>Distributor Technical Support</i>	3
1.3	EION PRODUCT INFORMATION	4
1.4	PUBLICATION HISTORY	4
<b>2</b>	<b>INTRODUCTION</b>	<b>1</b>
<b>3</b>	<b>PRODUCT DESCRIPTION</b>	<b>3</b>
3.1	RADIO COMPONENTS	3
3.2	RADIO CONNECTORS	4
3.3	POWER INSERTER UNIT	5
3.4	OUTDOOR INTERCONNECT CABLE	7
<b>4</b>	<b>VINE NETWORK TOPOLOGY AND OPERATION</b>	<b>9</b>
4.1	TOPOLOGY AND ANTENNA PORTS	9
4.2	TIME DIVISION MULTIPLEXING	9
4.3	NEW NODE ATTACHMENT AND VALIDATION	10
4.4	RF LINK PARAMETERS	11
4.4.1	<i>Dynamic Power Control</i>	12
4.4.2	<i>Enabling Dynamic Power Control from the Parent</i>	12
4.4.3	<i>Resetting the Link Margin from the Parent</i>	12
4.4.4	<i>Saving New Configuration</i>	13
4.5	CHANNEL ASSIGNMENTS	13
4.5.1	<i>Point-to-point</i>	13
4.5.2	<i>Point-to-Multipoint</i>	14
4.5.3	<i>Root-Repeater-Leaf</i>	14
4.5.4	<i>Small VINE network with up to three repeaters</i>	15
4.5.5	<i>Generic VINE network with multiple repeaters</i>	15
4.6	RF PLUG-AND-PLAY	16
4.6.1	<i>IP Address Assignment</i>	17
4.7	ETHERNET BRIDGING	17
4.8	QUALITY OF SERVICE	18
4.9	TYPE OF SERVICE	18
4.10	VLAN SUPPORT	19
4.11	DHCP CLIENT	20
4.12	WEB INTERFACE	20
4.12.1	<i>Web Browser Requirements</i>	20
4.12.2	<i>Logging into the Web Interface</i>	20
4.12.3	<i>Navigating the Web Interface</i>	21
4.12.4	<i>Web Interface Buttons</i>	22
4.12.5	<i>Configuring and Monitoring Radios with the Web Interface</i>	22
<b>5</b>	<b>ANTENNAS, SITE SELECTION, PATH ANALYSIS</b>	<b>23</b>
5.1	INTRODUCTION	23
5.2	SELECTING ANTENNA TYPE	23
5.2.1	<i>Directionality</i>	24

5.2.2	Gain .....	25
5.2.3	Polarization .....	26
5.3	SITE SELECTION .....	26
5.3.1	Line-of-Sight Path.....	27
5.3.2	Radio Horizon (Maximum Line-of-Sight Range).....	27
5.3.3	Point-to-Point Path Analysis .....	28
5.3.4	Antenna Orientation .....	34
5.3.5	Cable Loss (Attenuation).....	34
5.3.6	Connector Loss.....	35
5.3.7	Other Considerations – Antenna Grounding.....	36
<b>6</b>	<b>INSTALLATION AND SETUP .....</b>	<b>37</b>
6.1	BENCH CHECK OUT (USING RADIO ETHERNET CONNECTION).....	37
6.2	BENCH CHECK OUT (USING RADIO AUXILIARY PORTS).....	38
6.3	FIELD INSTALLATION .....	40
6.3.1	Antenna Installation .....	40
6.3.2	Antenna Alignment .....	40
6.3.3	Spectrum Analysis and channel selection.....	41
6.3.4	Output Power Limits (FCC).....	42
6.3.5	Output Power Limits (CE).....	43
6.3.6	Maximum Permissible Exposure (MPE) Limitations.....	43
6.3.7	Installing a Leaf Using RF Plug and Play.....	44
6.4	UPGRADING THE FIRMWARE .....	45
6.4.1	Description .....	45
6.4.2	Installing new firmware through the Ethernet port .....	46
6.4.3	Installing new firmware using FTP .....	48
6.4.4	Installing new firmware using Telnet .....	50
6.4.5	Installing new firmware using the RS-232 serial port.....	51
6.4.6	Feature upgrades.....	52
6.5	PASSWORD CONFIGURATION AND RECOVERY .....	52
6.5.1	Two-Tier Passwords .....	52
6.5.2	Change Passwords .....	52
6.5.3	Challenge Password Procedure .....	53
6.6	RUNTIME AND UPTIME CLOCKS .....	54
6.7	IP ADDRESS PROPAGATION .....	54
<b>7</b>	<b>COMMANDS.....</b>	<b>55</b>
7.1	CONFIGURATION TECHNIQUES.....	55
7.2	COMMAND SYNTAX.....	55
7.3	LICENSE KEY OPTIONS.....	57
7.4	CONFIGURATION MANAGEMENT COMMANDS .....	57
7.5	MAJOR CONFIGURATION PARAMETERS .....	60
7.6	BRIDGE MANAGEMENT COMMANDS .....	65
7.7	INTERNET PROTOCOL (IP) MANAGEMENT COMMANDS.....	70
7.8	VLAN COMMANDS .....	72
7.9	INSTALLATION AND LINK MONITORING COMMANDS .....	74
7.10	EVENT LOGGING COMMANDS .....	78
7.11	SCRIPTS .....	80
7.12	FILE UTILITIES .....	80
7.13	MISCELLANEOUS COMMANDS .....	83
<b>8</b>	<b>NETWORK MANAGEMENT.....</b>	<b>87</b>
8.1	TELNET .....	87
8.1.1	General.....	87
8.1.2	Starting a Telnet Session .....	87
8.1.3	Telnet Security.....	88
8.2	SNMP .....	88

8.2.1	<i>Command Line Interface Versus SNMP</i> .....	88
8.2.2	<i>What is SNMP?</i> .....	89
8.2.3	<i>Security Considerations in SNMP</i> .....	89
8.2.4	<i>Examples of Network Management Systems</i> .....	90
8.2.5	<i>VIP 110-24 Management Information Base (MIB)</i> .....	90
8.3	FTP .....	91
8.3.1	<i>File Transfer Protocol</i> .....	91
8.3.2	<i>Using FTP with the VIP 110-24</i> .....	91
8.4	WEB DOWNLOAD .....	91
8.4.1	<i>Web Download Syntax</i> .....	91
8.5	EMAIL ALARM CLIENT .....	92
<b>APPENDIX A – COMMAND SUMMARY (ALPHABETICAL)</b> .....		<b>95</b>
<b>APPENDIX B - COMMAND SUMMARY (FUNCTIONAL)</b> .....		<b>99</b>
<b>APPENDIX C - SPECIFICATIONS</b> .....		<b>109</b>
<b>APPENDIX D – CHANNEL FREQUENCY ASSIGNMENT</b> .....		<b>111</b>
<b>APPENDIX E – INTERCONNECT CABLES</b> .....		<b>115</b>

# **1 Important Information**

## **1.1 Safety Considerations**

This documentation must be reviewed for familiarization with the product, instructions, and safety symbols before operation.

Verify that a uninterruptible safety earth ground exists from the main power source and the product's ground circuitry.

Verify that the correct AC power source is available for the AC adapter to produce 24 Vdc output from the adapter.

Disconnect the product from operating power before cleaning.

## **Warning Symbols Used in this Book**

 **WARNING:** Bodily injury or death may result from failure to heed a **WARNING**. Do not proceed beyond a **WARNING** until the indicated conditions are fully understood and met.

 **CAUTION:** Damage to equipment may result from failure to heed a **caution**. Do not proceed beyond a **CAUTION** until the indicated conditions are fully understood and met.

**Important:** Indicates important information to be aware of which may affect the completion of a task or successful operation of equipment.

### **WARNING**

All antennas and equipment must be installed by a knowledgeable and professional installer.

### **CAUTION**

Never operate a unit without an antenna, dummy load, or terminator connected to the antenna port.

Operating a unit without an antenna, dummy load, or terminator connected to the antenna port can permanently damage a unit.

### **Important**

Antennas must be selected from a list of EION approved antennas.  
See [EION Approved Antennas](#), page 24 for list.

## 1.2 Notices

### 1.2.1 Copyright Notice

Copyright© 2010 EION, Inc.

All rights reserved.

This guide and the application and hardware described herein are furnished under license and are subject to a confidentiality agreement. The software and hardware can be used only in accordance with the terms and conditions of this agreement.

No part of this guide may be reproduced or transmitted in any form or by any means electronic, mechanical, or otherwise, including photocopying and recording without the express written permission of EION, Inc.

While every effort has been made to ensure that the information contained in this guide is correct, EION, Inc. does not warrant the information is free of errors or omissions.

Information contained in this guide is subject to change without notice.

### 1.2.2 Regulatory Notice

The VIP 110-24 product presented in this guide complies with the following regulations and/or regulatory bodies.

- RSS-210 of Industry Canada ([www.ic.gov.ca](http://www.ic.gov.ca))
- FCC Part 15 ([www.fcc.gov](http://www.fcc.gov))

Operation is subject to the following two conditions.

- This device may not cause interference
- This device must accept any interference, including interference that may cause undesired operation of the device

This equipment generates, uses, and radiates radio frequency and, if not installed and used in accordance with this guide, may cause harmful interference to radio communications. However, there is no guarantee that interference will not occur in a particular installation.

If this equipment does cause harmful interference to radio or television reception, which can be determined by turning the equipment off and on, the user is encouraged to try to correct the interference by one or more of the following methods.

- Reorient or relocate the receiving antenna
- Increase the separation between the equipment and receiver

- Connect equipment to an outlet on a circuit different from that to which the receiver is connected
- Consult the dealer or an experienced radio/TV technician for help
- Selecting and testing different channels, if employing 2.4 GHz equipment

As the VIP 110-24 is used on a license-exempt, non-frequency coordinated, unprotected spectrum allocation, and thus can be subject to random unidentified interference, applications must not be those of a primary control where a lack of intercommunication could cause danger to property, process, or person. An alternative fail-safe should be designed into any system to ensure safe operation or shut down, should communication be lost for any reason.

### 1.2.3 Other Notices

- Changes or modifications to the equipment not expressly approved by EION, Inc., could void the user's authority to operate the equipment.
- Appropriately shielded remote I/O serial cable with the metal connector shell and cable shield properly connected to chassis ground shall be used to reduce the radio frequency interference.
- Radio frequency exposure limits may be exceeded at distances closer than 23 centimeters from the antenna of this device.
- All antenna installation work shall be carried out by a knowledgeable and professional installer.
- Use only a power adapter approved by EION Inc.

### 1.2.4 Warranty & Repair

Please contact the party from whom you purchased the product for warranty and repair information.

EION provides no direct warranty to end users of this product.

### 1.2.5 Customer Support Contacts

Users of EION equipment who require technical assistance must contact their reseller or distributor. For information on distributors in your area, please visit [www.eionwireless.com](http://www.eionwireless.com).

### 1.2.6 Distributor Technical Support

Distributors may contact EION's Technical Assistance Center for technical support on EION Wireless products. When requesting support, please have the following information available:

- Description of the problem
- Configuration of the system, including equipment models, versions and serial numbers.
- Antenna type and transmission cable lengths
- Site information, including possible RF path problems (trees, buildings, other RF equipment in the area)

- Configuration of units (base, remote, channels used, etc.) and Link Monitor statistics

Contact EION's Technical Assistance Center at the numbers listed below.

All Locations: Call: 1-403-273-5100  
Business hours: 8:00 a.m. to 4:30 p.m. Mountain Standard Time (GMT-7:00)

All locations Send an e-mail message to: techsupport@eion.com

### 1.3 EION Product Information

To obtain information regarding EION Wireless products, contact the EION Wireless distributor in your region, call 1-403-273-5100 to speak with an EION sales representative or visit our web site at [www.eionwireless.com](http://www.eionwireless.com).

### 1.4 Publication History

All software releases are placed on EION's website for customers to download. These are accompanied by a software bulletin that describes the nature of the updates contained in the release.

EION issues an updated manual with any software release that changes a command or adds a new feature (and associated commands). Software releases, which fix bugs but do not change commands, do not require a manual update.

Revision	Date	Software Rev	Description
Rev D	APR 2002		Initial release of manual
Rev E	SEPT 2002		Software features added, Cloning, CIR and Hardware
Rev G	JUN 2004	2.50.3	
Rev H	JAN 2005	2.50.11	FTP Server functionality added.
Rev J	FEB 2007	2.60.00	Release 2.1.0 Feature Key
Rev K	JUL 2007		
Rev L	FEB 2010		Product Clarifications

## **2 INTRODUCTION**

The **VIP 110-24** is the building block of the proprietary **VINE** Network topology. The **VIP 110-24** is used to interconnect Ethernet **LAN's** (Local Area Networks) and **WAN's** (Wide Area networks) across large distances, creating a virtual single network. This unique network topology can also be used to provide broadband internet access by a Service Provider or to interconnect multiple nodes in a private network.

The VINE technology allows a complete wireless network to start with as little as two radios, and gradually grow, a node at a time, into a very large and complex wireless network. New nodes can be added at any time with the sole requirement that they must have **line of sight** connectivity to another node already on the VINE. The new node, once attached, becomes a potential attaching point for other nodes.

VINE uses **time, frequency, and directional diversity** to coordinate the **Medium Access** for all the nodes. This well choreographed diversity allows multiple nodes to transmit without collisions in the same geographical area. This results in a very high air time utilization which translates into superior throughput performance.

VINE is designed to specifically address the following requirements:

- Gradual deployment and expansion
- Long distance between nodes
- **Non-Line Of Sight** (NLOS) connectivity through multiple hops
- Node by node **Quality Of Service Options**: Minimum and maximum user data rate settings separate for inbound and outbound traffic
- Highly efficient air time utilization
- Efficient delivery of broadcast traffic (necessary for network management)
- Fair network availability under heavy loads (a few nodes with heavy load must not *choke* the network availability to all other nodes)
- Independent RF data rates and power selection on each individual link.
- Self configuring allowing new nodes to be added with minimal configuration

The VINE network topology and protocol is explained in greater detail in chapter 3.

The **VIP 110-24** is a **Spread Spectrum transceiver** that implements the VINE protocol. The radio includes a 10/100-Base T Ethernet port for connection to the Local Area Network (LAN). Each radio operates in a **self-learning bridge** mode. Any Ethernet station connected to the local LAN can see all other stations connected to any of the other LANs at the remote sites. No special configuration of the user stations is necessary, as each of them believes that there is just one Ethernet.

The **VIP 110-24** is a **Spread Spectrum radio** operating in the **Industrial Scientific and Medical (ISM)** band from 2.400GHz to 2.4835 GHz. Spread Spectrum technology allows operation without a license with an output power of up to 23 dBm at speeds up to 11 Mbps (mega-bits per second).

With exception of the indoor power inserter, all of the **VIP 110-24** electronics are included in a watertight IP66 rated outdoor unit enclosure. A single CAT 5 cable carries the Ethernet data and DC

power to the outdoor enclosure. This architecture allows the radio to be mounted outdoors, in close proximity to the antennas, resulting in the following benefits:

- The radio **Low Noise Amplifier** (LNA) is as close to the antenna as possible. The RF cable between the antenna and the outdoor unit is usually short and therefore cable losses at 2.4 GHz are negligible. This improves the overall link margin.
- The unit **Power Amplifier** is also in close proximity to the antenna. All the power is delivered to the antenna with minimal losses in the cable.

The **VIP 110-24** also includes a number of unique features that make the unit easy to install and operate:

- Spectrum analysis capability with a graphical display of the energy in the RF band
- Web-Based Graphical User Interface for network management
- Automatic E-mail Alarms triggered by 13 different traps
- RF Plug-and-Play
- Accurate measurement of the **Receive Signal Strength** (RSS)
- Antenna Alignment Aid output, at the outdoor unit, with an audio pitch proportional to the RSS
- Multitude of frequency channels allow operation anywhere in the band
- Dual antenna port to support store and forward operation in the unique VINE network topology
- Remote configuration, from a single station, of all radios in a network
- Capability of downloading firmware updates over Ethernet and RF links
- Support for Network Management tools (Telnet and SNMP)

Refer to section 6.1 for a Quick Start guide to set up the radios.

### 3 PRODUCT DESCRIPTION

#### 3.1 Radio Components

Figure 3.1 below shows the components that are typically shipped with each **VIP 110-24** radio.

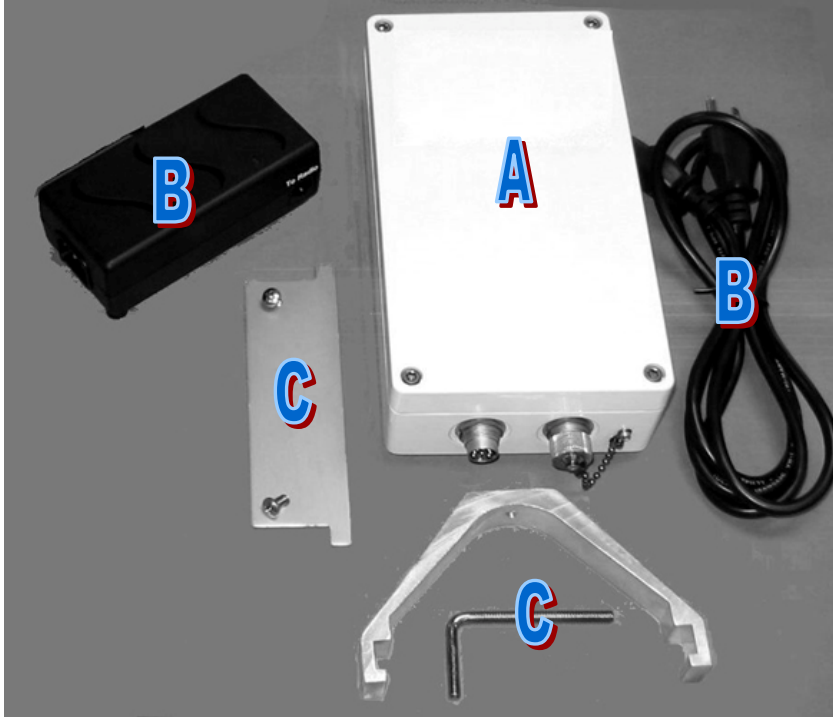

**Table 3.1 - VIP 110-24 Components**

A	VIP 110-24 outdoor unit. <sup>(1)</sup>
B	Power Inserter Module with AC power cord
C	Mounting Hardware for securing the VIP 110-24 unit to an outdoor mast.
-	Auxiliary port cable for RS-232 connection <sup>(2)</sup>
-	CAT 5 cable for connection between VIP 110-24 radio and power inserter module <sup>(2)</sup>

<sup>1</sup> Electronic version is available at [www.eionwireless.com](http://www.eionwireless.com).

<sup>2</sup> Not shown or supplied with standard radio kit. Available from EION as optional equipment.

### 3.2 Radio Connectors

Figure 3.2 shows the **VIP 110-24** radio mounted on a mast. The radio is housed in a rectangular enclosure with two **N-female** connectors at the top for connection to RF antennas, and two special purpose connectors at the bottom for DC power, Ethernet data and control.



**Figure3.2**

The function of each connector is described in the table below.

**Table 3.2 – VIP 110-24 Connectors**

CONNECTOR	TYPE	Function
A	N-FEMALE	2.4 GHz RF connector to the upstream (directional) antenna
B	N-FEMALE	2.4 GHz RF connector to the downstream (omni or sector) antenna
C	Switchcraft	Auxiliary port (3 pin) used as an antenna alignment aid and for RS-232 console port.
D	Switchcraft	10/100 Base-T data interface and DC power input (8 pin). Must be connected to the "Power Inserter Unit" with a CAT 5 cable.

An eight conductor CAT 5 cable must be connected between the **VIP 110-24** and the Power Inserter Unit. The wiring for this cable is shown in figure 3.3.

Table 3.3 shows the pin assignment of the three pin, auxiliary port connector. The unit is shipped with a cover in this connector. The connector can be used during installation as a console port and also as an audio antenna alignment aid. EION has available two cables to convert from this non-standard 3-pin connector to either a DE-9 connector (for RS-232 console) or to a standard audio jack (for connection to a headphone). See Appendix F for cable diagrams.

**Table 3.3 – Auxiliary Port Connector Pin Assignments**

Pin	Signal Name	Abbr.	Direction
1	Receive Data	RD	Radio Output
2	Transmit Data	TD	Radio Input
3	Ground	GND	

### 3.3 Power Inserter Unit

The Power Inserter Unit includes a power supply in a plastic enclosure equipped with two RJ45 connectors and a bi-color LED. The two RJ-45 connectors are labeled **To LAN** and **To radio**. The following tables describe those connectors.

**Table 3.4 – Power Inserter Unit**

Connector/LED	Type	Function
To LAN	RJ-45	10/100 Base-T to be connected to the Local Area Network. Use a straight through cable to connect to a hub and a cross over cable to connect directly to a computer. See table 2.5 for pin assignments.
To radio	RJ-45	Carries the DC power and Ethernet signals to the <i>VIP 110-24</i> . See table 2.6 for pin assignments.
LED	Amber/ Green	<b>Amber:</b> Indicates that the power inserter unit has AC power and is functioning but the <b>VIP 110-24</b> is drawing no power. <b>Green:</b> Indicates that the <b>VIP 110-24</b> is drawing power.

**WARNING**

The Power Inserter connector labeled **To radio** includes DC voltage on two of the pins. It must **not** be connected to a LAN as this voltage may damage some LAN cards.

**Table 3.5 – “To LAN” Ethernet Connector Pin Assignments**

Pin	Signal Name	Abbr.	Direction
1	Ethernet Tx	Tx (+)	Radio to Ethernet
2	Ethernet Tx	Tx (-)	Radio to Ethernet
3	Ethernet Rx	Rx (+)	Ethernet to Radio
4	(not connected)		
5	(not connected)		
6	Ethernet Rx	Rx (-)	Ethernet to radio
7	(not connected)		
8	(not connected)		

**Table 3.6 – “To radio” Ethernet Connector Pin Assignments**

Pin	Signal Name	Abbr.	Direction
1	Ethernet Tx	Tx (+)	Radio to Ethernet
2	Ethernet Tx	Tx (-)	Radio to Ethernet
3	Ethernet Rx	Rx (+)	Ethernet to Radio
4	+18 VDC	DCV (+)	Power Inserter to Radio
5	+18 VDC	DCV(+)	Power Inserter to Radio
6	Ethernet Rx	Rx (-)	Ethernet to Radio
7	18 VDC ground	GND(-)	Power Inserter to Radio
8	18 VDC ground	GND(-)	Power Inserter to Radio
Shield	Drain		Drain from Shield

### 3.4 Outdoor Interconnect Cable

The interconnect cable between the Power Inserter Unit and the **VIP 110-24** is shielded. It carries the following signals

1. DC voltage to supply power to the **VIP 110-24**.
2. 10 Base-T Ethernet data.

Both these signals are carried in a single CAT 5 cable. The system is designed to allow cable lengths up to 100 meters (300 feet). Figure 2.3 shows the interconnect diagram for this cable and connector types. Table 3.7 lists a part number and sources of appropriate CAT 5 cable for this application. EION Wireless. carries several pre-made cables of different lengths. See Appendix E for connector diagrams, part numbers, and assembly instructions.

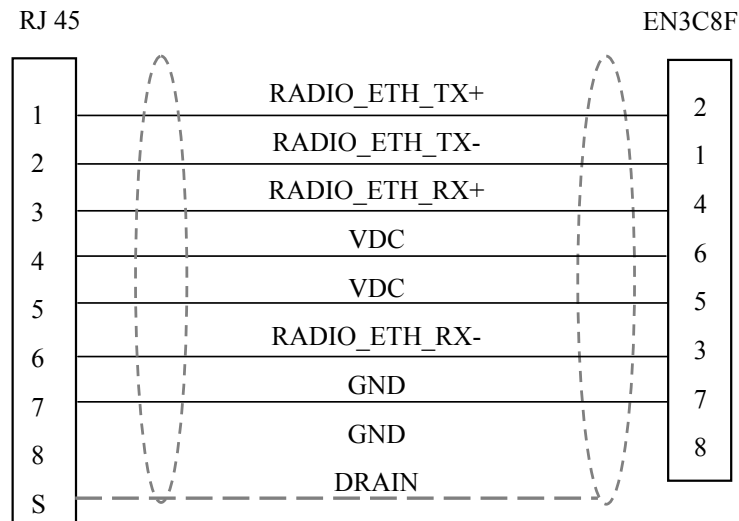

**Figure 3.3 – CAT 5 Outdoor Interconnect cable diagram**

**Table 3.7 – Outdoor Unit CAT 5 cable**

<b>Part number</b>	<b>Manufacturer</b>	<b>Description</b>
7919A	Belden	Industrial shielded, weatherproof cable for aerial and other severe environments

## **4 VINE NETWORK TOPOLOGY AND OPERATION**

### **4.1 Topology and Antenna Ports**

The **VIP 110-24** is the building block of the VINE wireless network. This unique architecture allows nodes to be added to the network by establishing a connection to any node already on the network. Once attached, the new node becomes the potential attaching point for other nodes.

The VINE network topology is a **tree**. The different node types in the tree are: **root**, **repeater**, and **leaf**. Figure 4.1 below, illustrates a possible network. Figure 4.2 shows a graph representation of the same network.

The **VIP 110-24** is equipped with two antenna ports. **Antenna port A** is assigned for communications with that node's **parent**. With exception of the root, **each node in the VINE has one and only one parent node**. The antenna connected to port A is typically a **high gain directional** antenna pointing at this parent node. The **root** node is the **only** radio without a parent node.

**Antenna port B** is assigned for communications with the node's **children**. This antenna must provide coverage to **all** of the node's children. Depending on the geographic location of those children the antenna connected to port B could be an **omni**, **sector**, or **directional** antenna. **Leaf** nodes do not have children, so no antenna is connected to port B.

Each **VIP 110-24** in a VINE network operates in a half duplex mode, i.e., it may either transmit or receive at any given time. Transmissions consist of variable length packets. **Outbound** packets flow **downstream** or away from the root (from parent to child). **Inbound** packets flow **upstream** or towards the root (from children to parent).

### **4.2 Time Division Multiplexing**

Within each **branch** in a VINE network (defined as the parent radio together with its children that are one hop away), the parent services all its children by **polling** each one in turn. The poll/response is very rapid with very short timeouts. When a radio does not have any traffic to transmit downstream or upstream it takes very little time away from the polling cycle. This **TDD** scheme allocates the available bandwidth to the active radios only.

In a VINE network with multiple repeaters, the various parent nodes in each branch run their master cycles asynchronously from each other. However, the complete VINE has an underlying synchronization mechanism that allows repeaters to switch between being a **parent** and a **child** at the appropriate times.

Packets can flow up or down the tree, with each radio forwarding the packet through the appropriate antenna or Ethernet port depending on its destination.

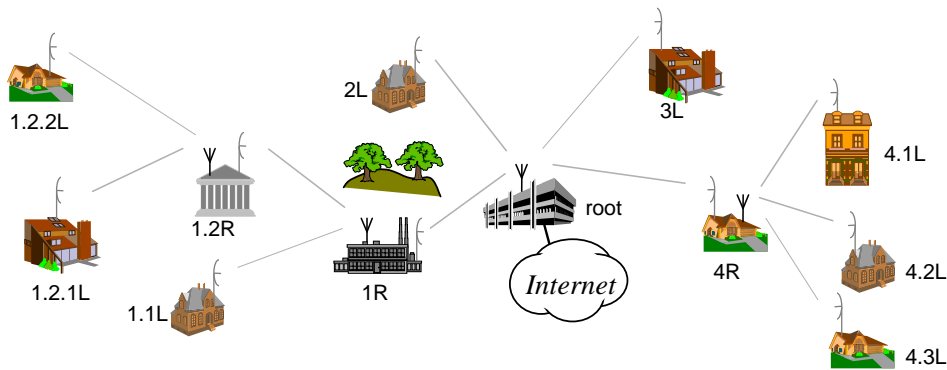

Figure 4.1 – VINE network topology

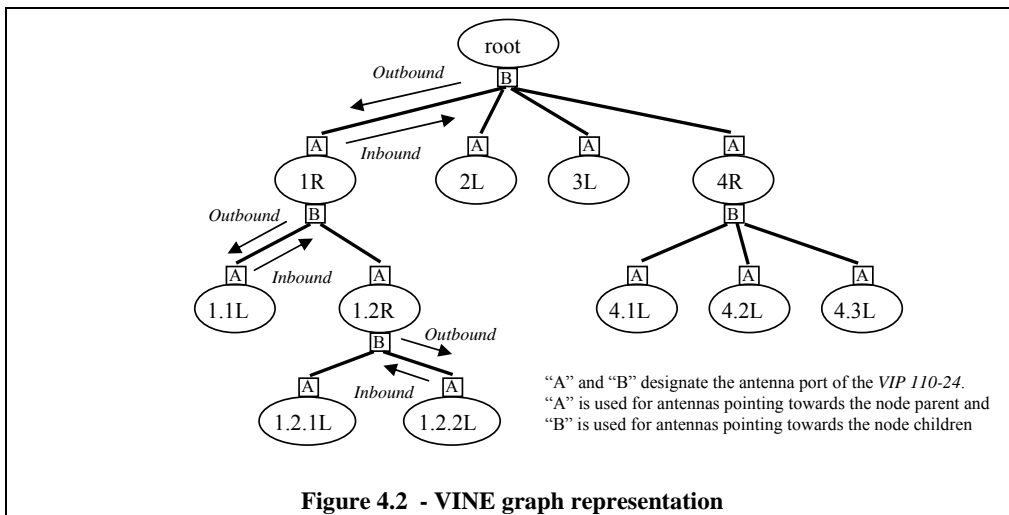

Figure 4.2 - VINE graph representation

**Node naming convention for figure 3.2**

1. Designate the root node as **root**.
2. Number all nodes one-hop away from the root (referred to as its **children**) sequentially starting at 1.
3. Name all the children of each repeater by giving them the parent number and appending a sequential number starting at 1 (use a . to separate the parent designator from the child number).
4. Repeat step 3 until all nodes are named. Add an **R** or an **L** to the end of the designator to indicate whether the radio is a repeater or a leaf.

**4.3 New Node Attachment and validation**

Besides polling the known child radios, nodes configured as root and repeater continuously search for **new** child nodes. This is done by periodically broadcasting a **New Node Poll (NNP)** packet. When a

new leaf or repeater node is turned **on**, it first listens for a short period, on antenna A, for NNP packets from any potential parent. If the node receives NNPs from more than one parent it selects the parent with the **strongest** signal. It then attempts to attach to the network by transmitting an **Attach Request** packet in response to the next NNP packet from that parent.

When a parent receives an **Attach Request** from a new radio, it first authenticates the new node by validating the **Network ID** supplied in the **Attach Request** packet. In this attachment handshake the nodes also pass information about the RF link parameters (channel, speed and power) to be used in the RF transmissions in each direction. Once attached, if the new node is configured as a repeater, it will start broadcasting New Node Polls to search for children of its own.

This scheme allows any node to be added to the network by simply programming its **Network ID**, pointing the antenna A to the appropriate parent, and turning the power **on**. Within a few seconds the new node establishes contact with the parent and the node is attached. There is no need to change the configuration at any other node in the network.

#### 4.4 RF Link Parameters

Within each link there are three configurable RF parameters: **transmit power**, **RF speed**, and **frequency channel**. These parameters are configured independently for each direction of the link. The commands that allow programming these parameters are **rf-from-parent**, **rf-from-children**, **rf-to-parent**, **rf-nnp-1**, and **rf-nnp-2**.

The transmit power can be configured from 0 to 23 dBm in steps of 1 dB. For each link, the RF transmit power should be kept as low as possible while still providing adequate link margin. This reduces the potential for self-created interference with other radios in the VINE network that are using the same channel. If there is no interference from other sources, a signal level at the receiver of around -60 dBm provides ample margin for a reliable link.

The speed of the link can be configured to **1**, **2**, **5.5** and **11** Mbps. The RF speed should be configured to 11 Mbps unless, after increasing the power to its maximum level, the link margin is still not adequate. Reducing the RF speed improves the radio sensitivity, providing a better RF link margin.

The transmit power and speed (in each direction) are always stored in the configuration of the child radio. Since each radio has one and only one parent, this scheme allows each radio to be responsible to store the parameters for one link only.

The channel used in each link is selected and stored in the configuration of the receiver side of the link (with some restrictions). This allows the receiver to select the most favorable channel based on its local conditions, and then tell the radio at the other side of the link what channel to transmit. A parent radio receives from all its children on antenna B, therefore the most favorable channel is independent of which child is transmitting. This channel is selected, at the parent, with the command **rf-from-children**. Parents include this channel number in the **New Node Poll** packet so that there is no need to store this transmit channel at the child.

A child radio receives from the parent on antenna A. The local conditions at each child location may be different, so a parent may transmit to different children on different channels. However, for a link to get established in the first place, the parent must transmit the **New Node Poll** packets on a channel known by the prospective children. To give the children a choice of channels the parent can be configured to transmit NNPs in two separate channels (see commands **rf-nnp-1** and **rf-nnp-2**). At the child node, the receive channel is configured with the command **rf-from-parent**. For the

child to get attached, **the child receive channel must match one of the two NNP channels of the parent.**

#### 4.4.1 Dynamic Power Control

Every radio, whether it is a Root, Repeater or Leaf has the ability to assess and compensate for varying received Radio Frequency (RF) levels at each radio, so that all the units in your network are operating optimally: this feature is called Dynamic Power Control.

Link Margin—the key component in Dynamic Power Control—is the difference between the sensitivity level, called the Bit Error Rate (BER) point and the current signal strength to and from a radio, called the Received Signal Strength Indicator (RSSI). The link margin ensures that no radio transmits at power levels too high or too low, which allows seamless network operation and consistent dependable access for users.

The BER determined by the RF Speed. For instance, if you have an 11 Mbps radio, then your BER is -81 dBm.

For example:

An 11 Mbps radio with a BER point of -81 dBm has a minimum acceptable level of -81 dBm. Setting the Link Margin to 12 dB will cause the radio to maintain an RSSI of -69 dBm.

Again, for the same radio, if the RSSI exceeds -69 dBm plus 2 dB the radio receiving the signal will reduce power until the RSSI is back at -69 dBm.

**Radio RF Speed and the Corresponding BER**

<b>If the RF Speed is</b>	<b>Then the BER will be</b>
11 Mbps	-81 dBm
5.5 Mbps	-84 dBm
2 Mbps	-87 dBm
1 Mbps	-91 dBm

#### 4.4.2 Enabling Dynamic Power Control from the Parent

1. Log in to a unit.
2. At the prompt, enter  
*rffp dpc=enable*

#### 4.4.3 Resetting the Link Margin from the Parent

The Link Margin has a default setting of 12 dB. If you need to reset the Link Margin to optimize network planning

1. Log in to a unit.
2. At the prompt, enter  
*rffp lm=<new link margin>*

#### 4.4.4 Saving New Configuration

To make changes to the link margin setting permanent, you must save your configuraton.

1. At the prompt, enter  
`sc`

You can configure Dynamic Power Control independently from a Parent and to a Parent through *rffp* and *rftp*. However, these changes only affect the link between a radio and its Parent, so therefore has no effect on Root radios.

### 4.5 Channel Assignments

In a VINE network, multiple radios in the same geographic area may be transmitting simultaneously. Without careful coordination this could generate interference between links. The *VIP110-24* capability of transmitting and receiving in different channels through its two antennas allows it to optimize the channel assignment to avoid this potential interference.

The radio factory configuration sets the **outbound** and **inbound** channels to two non-overlapping frequencies. For a generic VINE network with multiple repeaters, this approach, coupled with directive antennas on antenna A, greatly reduces the potential for self generated interference (see section 4.5.4). Even though this **channel plan** will work in any topology, there are some simpler networks where it may be desirable to use a different channel plan. The following sections describe some simple topologies and discuss the channel assignment considerations. The table below each topology shows the commands required, at each node, to set the channel assignments.

#### 4.5.1 Point-to-point

In a point-to-point network one radio is configured as the root (with the antenna on port B) and the other as a leaf (with the antenna on port A). If there is no external interference at either end of the link, and it is desired to conserve bandwidth, you may configure the radios to use the same channel in both directions. If there is interference on difference regions of the spectrum, at each end of the link, configure the radios to use different channels in each direction. Since channels are allocated 2 MHz apart this allows centering the RF transmission anywhere in the ISM band.

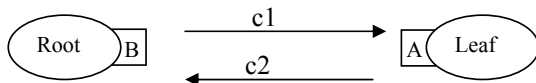

Root	Leaf
<code>rf-nnp-1 ch=c1</code>	<code>rf-from-parent ch=c1</code>
<code>rf-from-children ch=c2</code>	

### 4.5.2 Point-to-Multipoint

In the point to multipoint topology, the hub radio is configured as the **root** and receives from all its children in a single **inbound** channel. All remote radios are configured as **Leaf**. The network may be configured with up to two different outbound channels, which may or may not overlap with the inbound channel. Configuring the root to send NNPs in two different outbound channels gives each child the choice of two receive channels depending on the local conditions. If this second outbound channel is not required, the transmission of NNP in a second channel may be disabled.

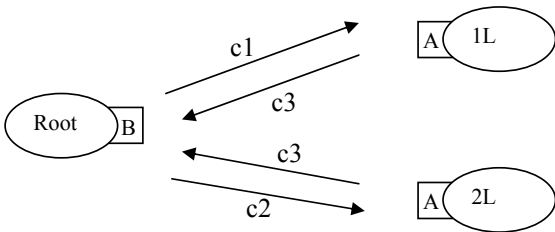

Root	1L	2L
rf-nnp-1 ch=c1	rf-from-parent ch=c1	
rf-nnp-2 ch=c2		rf-from-parent ch=c2
rf-from-children ch=c3		

### 4.5.3 Root-Repeater-Leaf

This is the simplest configuration involving a radio configured as a repeater. There are four channels to consider. Since there are two possible **parents** (root and repeater) there may be simultaneous transmissions and therefore the potential for collisions. The two possible (but unlikely) collisions are the following:

1. At the repeater: While the repeater is trying to receive a packet from the leaf (on antenna B, channel c3), the root transmits a **Data Poll** to the repeater (on channel c1). If antenna B of the repeater is directional it may easily reject this unwanted transmission from the root. Otherwise ensure that c1 and c3 are non-overlapping.
2. At the leaf: While the leaf is trying to receive a packet from the repeater, the root transmits a **Data Poll** to the repeater. This could only be a problem if the leaf can see the root on its antenna A. If that is the case ensure that channels c1 and c2 are non-overlapping.

Since those situations are unlikely, all channels could be identical. If any of those conditions might occur, one simple approach is to assign a single frequency to the root/repeater links (c1=c4) and a

separate, non-overlapping frequency, to the repeater/leaf links (c2=c3). If there is local external interference to be avoided all channels might be different.

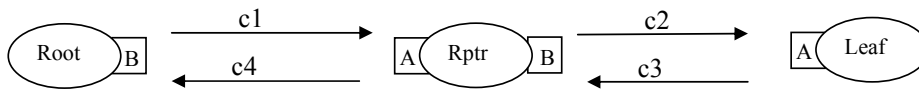

Root	Repeater	Leaf
rf-nnp-1 ch=c1	rf-from-parent ch=c1	
	rf-nnp-1 ch=c2	rf-from-parent ch=c2
rf-from-children ch=c4	rf-from-children ch=c3	

#### 4.5.4 Small VINE network with up to three repeaters

For VINE networks that are larger than the simple cases described above, but still with a small number of repeaters, one simple approach to avoid self-generated interference is to allocate a non-overlapping channel to each **parent**. Within each **branch** (made up of a parent and all its **one-hop** children), the same channel would be used for both inbound and outbound transmissions. Since the VIP can support up to 4 non-overlapping channels, this scheme works in networks consisting of a root and up to three repeaters.

#### 4.5.5 Generic VINE network with multiple repeaters

When a VINE network grows in complexity and includes multiple repeaters, the potential for self-generated interference increases. The way to reduce or avoid this self-generated interference is to allocate one channel to all outbound transmissions (from parents, through antenna B), and a separate, non-overlapping channel, for all inbound transmissions (from children, through antenna A). Since there may be some external local interference, this **channel plan** should also provide for a **secondary** set of channels. An example of a channel plan is shown below. The default factory configuration of the radios is set for this particular **channel plan**.

	Outbound	Inbound
<b>Primary:</b>	5	25
<b>Secondary:</b>	35	15

When this frequency diversity approach (non-overlapping inbound and outbound channels) is coupled with the directional nature of the antennas connected to port A, the potential for self-generated interference is greatly reduced.

The network in figure 4.1 shows why the inbound and outbound transmissions are assigned to different channels. For example, repeater **4R** may perform an outbound transmission, through an omni-directional antenna, at the same time that leaf **3L** performs an inbound transmission to the root. If the inbound and outbound were on the same frequency, there would be a collision at the root.

However, a transmission within any given **branch**, (defined as a parent radio together with its **children** that are only one hop away) will not interfere with simultaneous transmissions in any other branches. Any two simultaneous outbound transmissions in different branches will be received by the intended nodes due to the high gain antennas attached to port **A** of the downstream radios. Likewise, any two simultaneous inbound transmissions in different branches will be received by the intended upstream nodes due to the high gain of the antenna **A** pointed directly at the upstream radio. This scheme is further optimized by setting the transmit power in every link to achieve no more than the adequate link margin for that particular link.

There may be specific situations where the diversity achieved through the dual frequency operation and antenna directivity would not work. For example, if radios 1R, 1.2R, and 1.2.2L (figure 3.1) were in a straight line, inbound transmissions from 1.2.2L could reach 1R and interfere with a simultaneous inbound transmission from 1.1L. Those specific cases can be addressed with one or more of the following techniques:

1. Power management. Reduce the transmit power from 1.2.2L so that the signal at 1R is significantly below the signal from 1.1L
2. Additional channels. Use the **primary** set of frequency channels between 1R and its children, and the **secondary** (non-overlapping) set of channels between 1.2R and its children.
3. Antenna polarization. Use horizontal antenna polarization between 1.2R and its children, and vertical polarization between 1R and its children.

The VINE approach to frequency diversity allows deploying a system with radios transmitting simultaneously in the same geographic area, using only two non-overlapping channels for the entire RF network. This should be contrasted with a cell based approach where adjacent cells are typically allocated to different frequencies and may require four to six non-overlapping channels.

## 4.6 RF Plug-and-Play

RF Plug and Play enables you to install and configure a radio unit (Leaf) remotely, without having to connect to a computer. When you power up a Leaf it starts to scan for VIP frequency bands looking for New Node Polls being transmitted by Parents. When the Leaf finds a New Node Poll, it stores the channel number and Received Signal Strength Indicator (RSSI).

This feature uses the three pin "Auxiliary port" connector to output an audio signal with a pitch proportional to the receive signal strength. EION provides a special cable adapter that converts the three-pin connector into a standard female audio jack. Use this cable to connect the three-pin connector to a pair of standard headphones while aligning the antenna.

The Leaf plays a slow, steady tone—a ping and a pause—while the Leaf is searching the channels. The tone frequency is 800 Hz, and the cadence (speed of the tone) is a 250 milliseconds ping and 500

milliseconds pause—meaning there is a loop of a short ping with a long pause then another short ping.

When the Leaf detects a potential Parent with an RSSI of greater than  $-75$  dBm the ping and pause quickens.

Before choosing a Parent, the Leaf scans all the available channels three times looking for the strongest signal and averaging the RSSI of all the potential Parents it has scanned. When the Leaf determines which Parent has the strongest signal and provides the best link, and it sends an Attach Request.

When the potential Parent acknowledges the Leaf, the beep becomes a 2-tone warble, and the Leaf attempts the final steps in attaching to the Parent.

The Leaf will use the IP address set in its configuration or will attempt to acquire an address via DHCP if DHCP is enabled. Next it attempts to download a configuration (config) file from the Parent. The Leaf then performs a run script command with the downloaded config file.

If the attempt to attach to the Parent is successful, the Leaf creates a strong steady tone. If the Leaf can't attach to the Parent, it stops all tones, and you need to cycle to power and start the procedure over.

When the Leaf plays a strong, steady tone, adjust the direction of the antenna a few degrees to the right and left to locate the steady tone with the highest pitch. The higher the pitch of a steady tone, the stronger the RSSI signal. The strongest RSSI signal provides the best connection and performance. When the strongest signal is found, you stop and lock the antenna and the link is secure.

#### 4.6.1 IP Address Assignment

RF Plug and Play can be used in conjunction with DHCP. If the leaf is originally configured for DHCP, it will attempt to acquire an address from a DHCP server as soon as it is attached to a parent. If the initial configuration of the leaf does not have DHCP enabled, the pre-configured IP address will be used when downloading the configuration script.

The configuration script the leaf downloads from the parent is based on the configuration of the parent. If the parent has DHCP enabled, the leaf will also use DHCP. To use DHCP on the leaf, it must be enabled on the parent.

If DHCP is not being used with RF Plug and Play, the leaf must be pre-configured with its own unique IP address before being installed.

## 4.7 Ethernet Bridging

The *VIP 110-24* operates as an Ethernet bridge. As a bridge, the *VIP 110-24* runs in **promiscuous mode**; that is, it examines all the Ethernet packets that are flowing in the local LAN. Since these Ethernet packets contain a **source** and **destination** address, the radio quickly learns the addresses of all the **local** stations connected to the LAN (all the **source** addresses of packets flowing in the LAN are local).

Each *VIP 110-24* in the VINE periodically transmits the information about the local Ethernet addresses to all other radios. Therefore every *VIP 110-24* holds an Ethernet table that includes one

entry for every Ethernet address connected to any of the LANs. This table can be examined with the `show ethernet` command.

With this information on hand, each *VIP 110-24* examines the destination address of every Ethernet packet in the local LAN and makes one of the following decisions:

1. If the destination address is for a **local** station, discard the packet.
2. If the destination address is connected to a remote radio, queue that packet to be forwarded through the appropriate RF port.
3. If the destination address is unknown, **flood** the packet into the VINE network. The packet will show up at every LAN connected to any radio in the VINE.

Each *VIP 110-24* has capacity to store 500 entries in its Ethernet table. Entries are erased after a certain amount of time to allow for stations to be moved between LANs and not show up in two distinct LANs. The user can control this time-out with the `ethernet` command. If the table ever gets full, entries that have been least used are erased to make room for new entries.

Bridging has two major advantages over routing:

1. There is absolutely no configuration required. The *VIP 110-24* learns about all stations automatically and routes the packets appropriately.
2. All **Layer-3** protocols (IP, IPX or others) can be bridged.

## 4.8 Quality of Service

The VINE protocol is ideal for bursty traffic that is typical in data communications. The available data throughput is allocated on demand to the nodes that are **active**. If the network gets congested, there are different **QoS** (Quality of Service) parameters that allow the network manager to give priority to certain nodes. Using the different type of service (ToS) settings, priority can be assigned for voice, video or multimedia traffic. Nodes with a **committed information rate** (CIR) will always have access to the committed bandwidth. When those nodes are not using their committed bandwidth, it becomes available to be shared among all nodes. The unique VINE flow control mechanism adaptively shares this excess bandwidth equally among all active nodes without a CIR.

In an Internet Access application, one of the nodes is connected to the wired Internet. In a VINE network this node is designated as the **anchor**, and it is where a large majority of the traffic will originate and converge. For these applications it is typically desirable (but not required) to make the root node the anchor.

## 4.9 Type of Service

The VIP offers priority queuing based on the **Type of Service** field of Ethernet packets. Enhanced priority queuing provides three levels of priority to Ethernet packets traveling through your VIP network. Packets are placed in priority queues based on their Type of Service (ToS) and VLAN priority settings.

Three queues determine what order traffic is placed in the RF queue.

Priorities for both VLAN and ToS are:

- 0–3 is low priority and is sent to the low priority queue
- 4–5 is medium priority and is sent to the medium priority queue
- 6–7 is high priority and is sent to the high priority queue

Packets with a VLAN tag of 0–3 are low priority unless the ToS priority is greater than 3. If this is the case, the packets priority is determined by the ToS priority. When the network is congested and the flow control mechanism limits the number of packets that each radio can offer, the lower-priority packets are dropped before the higher priority packets.

It should be noted that All **VIP** traffic in the network is considered high priority regardless of VLAN or ToS priority settings.

## 4.10 VLAN Support

VLAN allows the network administrator to plan and segment a network into multiple Local Area Networks (LAN) at a Leaf, a Repeater, or a Root. Through the use of VLAN tagged Ethernet packets and the processing rules the radio applies—rules that you define in the tables—you can determine access and traffic patterns, and increase network security without the use of additional hardware.

VLAN allows you to define a group of users with a VLAN Identification Number. Radios or computers in that group—even those using a wireless connection—can communicate securely over a LAN without being seen by any other group or individual using the network.

All Ethernet packets sent over a network are tagged. Basic Ethernet tags contain 4-bytes of information:

- Destination Address
- Source Address
- Length
- Type

With VLAN Ethernet frames using Ethernet II framing have the EtherType value in the Ethernet header set to Tag Protocol ID (TPID) hex 8100. This identifies the frame as an 802.1Q frame. An extra two-bytes called Tag Control Information (TCI) is inserted after the TPID, followed by another two bytes containing the frame's original EtherType. Together the four bytes of TPID and TCI are called the VLAN tag.

The two byte TCI contains;

- user\_priority (3 bit field)
- Canonical format indicator (CFI) (1 bit field)
- VLAN ID (VID) (12 bit field)

Please refer to section **7.8 VLAN Commands** for a full listing of the VLAN commands available with the VIP.

## 4.11 DHCP Client

The VIP 110-24 can obtain and renew an IP address automatically through DHCP Client. When the DHCP Client is enabled on a radio, the DHCP continually sends discover messages until it receives a response from a DHCP server. When a response is received, the DHCP Client attempts to acquire an IP address, a subnet mask, and a gateway address.

If the attempt is successful, DHCP will sleep until renewal time—usually 50% the lease time. At renewal time, DHCP renews the address from the server that assigned its IP.

If the renewal attempt is unsuccessful, DHCP continues to try to renew. If renewal attempts are unsuccessful by rebinding time—usually 87.5% of lease time—the client attempts to discover a new DHCP server to obtain an IP.

Please refer to section 7.7 Internet Protocol (IP) Management Commands for a full listing of the DHCP commands available with the VIP.

If an address is not successfully acquired within approximately 5 minutes, the IP address will be set to the pre-configured IP address. DHCP discovery will continue even after this address is restored.

## 4.12 Web Interface

The VIP 110-24 Web Interface is a Graphical User Interface (GUI) that gives you all the options and functionality for configuring and monitoring radios in your network as the Command Line Interface (CLI), but in a familiar point and click web environment.

### 4.12.1 Web Browser Requirements

The minimum Web Interface requires that your Internet browser supports Java Script frames.

### 4.12.2 Logging into the Web Interface

1. To log into the Web Interface, enter the VIPs IP Address in the Address Bar of a web browser. Typing *http://* ahead of the IP address is not necessary.

A login Screen opens:



2. In the User Name field enter vip.  
You cannot change the User Name.
3. In the Password field enter the enable-configuration password. If you want to change the password, you must change the enable-configuration password with the change password command.

### 4.12.3 Navigating the Web Interface

Navigating through the Web Interface is simple and intuitive. The Navigation bar on the left side of the page acts as an interactive table of contents that allows you to choose and open any page you need to configure or monitor the radios in your network.

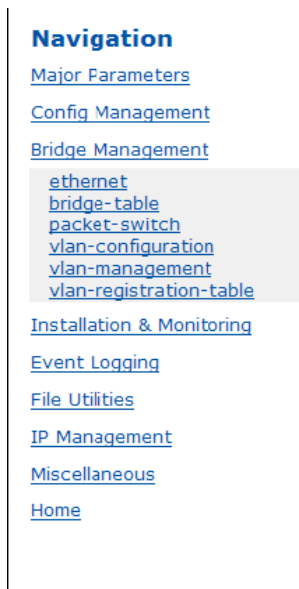

The navigation menu enables you to quickly view any setting or configuration page.

All the headings have sub-menus that allow you to perform specific configuration tasks, or to view radio and network information.

1. To view a sub-menu, click on the heading.
2. To open a setting or configuration page, click on the sub-menu item.

#### 4.12.4 Web Interface Buttons

**Submit** updates the changes you have made to the current configuration.

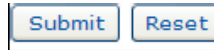

**Reset** returns the settings to their previous state.

**Save** writes the changes you have made to radio or network settings or configuration to EEPROM.



**Restore** returns the radio or network configuration to the last saved state.



**Factory** returns the radio or network configuration to factory or pre-installation settings.

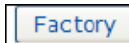

#### 4.12.5 Configuring and Monitoring Radios with the Web Interface

The Web Interface enables you to view current radio configuration, and make changes and updates quickly and easily.

Every page is set up with a table that displays the current configuration. The table headings provide configuration information and details that define and explain the commands and parameters. The main table headings are:

- Values—Values displays the current value the radio uses.
- Units—Units displays the unit of measurement, for example, dBm or ms.
- Range—Range displays the allowable range for the value.
- Details—Details provides a specific explanation for each field.

## **5 ANTENNAS, SITE SELECTION, PATH ANALYSIS**

### **5.1 Introduction**

#### **NOTE**

Basic instructions for connecting the antenna to the radio are given in Section 6. If the system is to be used at short to moderate ranges and there are no major obstructions between antennas, the more detailed information in this section may not be necessary.

Because *VIP 110-24* radios communicate with each other by means of radio waves, all aspects of antenna installation affect their performance significantly, namely:

- antenna type used
- clear line-of-sight path between antennas
- antenna orientation
- antenna placement
- antenna-to-antenna distance between radios
- distance between the radio and its antenna (antenna cable length)

Therefore antenna installation is a vital part of system installation. Improper installation may greatly reduce system performance, possibly rendering the system inoperable.

This section discusses these issues and provides guidelines for selecting antenna type, selecting antenna location, and achieving an optimally functioning installation.

### **5.2 Selecting Antenna Type**

There are a vast number of antenna types designed for various general and special purposes, but despite the huge variety, all designs essentially address two concerns, directionality and gain. These selection criteria are discussed in the following paragraphs, along with a third criterion, polarization.

For the *VIP 110-24*, the following antenna types listed below will fulfill most installation requirements.

Antenna Type	Gain	EION Part Number
Omnidirectional	10 dBi	1200-0211
Sector 90°	12 dBi	1200-0422
Grid 13°	17 dBi	1200-0308
7.5° Parabolic dish	24 dBi	1200-0309
18° Parabolic dish	19 dBi	1200-0310
13.5° Parabolic dish	21 dBi	1200-0311
47° Shrouded Yagi	11.5 dBi	1200-0330
FA Sectoral	17.5-13 dBi	1200-0332
90° Sectoral Horizontal	12 dBi	1200-0422
18° Parabolic dish w/ Radome	19 dBi	1200-0507
13.5° Parabolic dish w/ Radome	21 dBi	1200-0508
180° Sectoral	10 dBi	1200-0512
FA Sectoral	15-10.5 dBi	1200-0513

### 5.2.1 Directionality

An antenna may be designed to receive and transmit in all directions. Such antennas are **omni-directional**. An example of an omni-directional receiving antenna would be a television antenna in a metropolitan area where each television station transmits its signal from a different location relative to the receiver. Similarly, a centrally located television transmitter would use an omni-directional transmitting antenna.

The sensitivity and power of an omni-directional antenna are unfocused; that is, they are spread through a wide volume of space, so the advantage of being able to communicate in all directions is traded off for limited sensitivity and power.

If it is determined that all signals of interest are coming from a definable direction, the omni-directional antenna can be replaced by a **directional** or **sectoral** antenna, which increases sensitivity and power by focusing the beam in the desired direction.

In practice, even omni-directional antennas take advantage of directionality by focusing their sensitivity and power in the horizontal plane. Rather than waste performance by sending signals into space or into the ground, the **horizontal omni-directional** antenna redirects its power and sensitivity from these directions, increasing performance in the horizontal plane.

An omni-directional antenna is used with a VIP 110-24 unit for typical VINE networks where a given radio must communicate with a variety of **downstream** radios in various directions.

In point-to-point applications, where the direction of communication is known and fixed, a highly focused **directional** antenna can be used to provide maximum sensitivity and power. In addition, because of its decreased sensitivity in all directions but the desired one, the directional antenna improves performance by rejecting signals **not** coming from the desired direction. This provides an effective increase in signal-to-noise performance.

A **sector** antenna has a wider **spread** than a **directional** (generally between 60 to 120 degrees) which makes it a cross between an omni-directional and a directional. This is useful in a point to multipoint configuration where multiple sites are grouped in the same general area. The installer can then make use of the higher sensitivity and power but also take advantage of the wider beam pattern and improved front to back ratio.

### 5.2.2 Gain

**Gain** specifies the receive and transmit performance of any antenna compared to a standard omni-directional antenna (**spherical radiator**). The objective of a directional antenna design is to achieve gain, improving sensitivity and effective radiating power to increase range or data rate.

Gain is measured and stated in decibels, abbreviated as **dB**. The **decibel** is a unit used to indicate the **relative difference** in power between two signals. For example, a signal that is 3 dB greater than another signal has twice as much power. The decibel is a logarithmic unit so each doubling of decibels represents a fourfold increase in power. Since 3 dB represents a doubling of power, 6 dB represents a fourfold power increase, 12 dB represents a 16-fold increase, etc. For antenna performance, the unit used is **dBi**, in which **i** stands for **isotropic** which describes the standard spherical radiation pattern.

One type of directional antenna available from EION Wireless is called a **semi-parabolic**. This antenna has a gain of 24 dBi, representing power and sensitivity levels 256 times greater than those of a standard omni-directional antenna.

For omni-directional coverage from fixed locations, EION Wireless provides **collinear** antennas. The collinear design achieves gain by increased focus in comparison with the dipole design. The standard collinear antenna used with the VIP 110-24 provides 9 dBi gain, representing an eight-fold power and sensitivity increase.

### 5.2.3 Polarization

Another important concept for antenna performance is **polarization**. An antenna radiates radio waves that vibrate in a specific plane, normally horizontal or vertical. Polarization refers to the restriction of wave vibration to a single plane.

#### **NOTE**

Do not confuse polarization with directionality. The plane of wave vibration has nothing to do with the direction of wave propagation. For example, an antenna that focuses its energy in the horizontal plane may be vertically or horizontally polarized.

Designs such as the semi-parabolic offer a choice of polarization. Mounting a semi-parabolic antenna with the elements horizontal provides horizontal polarization, while mounting the antenna with the elements vertical provides vertical polarization. Similarly, the orientation of the radiating element of the parabolic antenna determines polarization.

In setting up the *VIP 110-24* system, either vertical or horizontal polarization can be used, as long as polarization is the same at both ends of each link. For any given pair of line-of-sight antennas, it is essential that they both have the same polarization. Differences in polarization among antennas, called **cross-polarization**, can reduce signal considerably.

## 5.3 Site Selection

At the high operating frequencies of the *VIP 110-24* system, radio waves travel in a nearly straight line-of-sight path. This is in contrast to the lower-frequency radio waves used for AM broadcasting. These waves bounce between the ionosphere and the earth's surface to travel long distances and operate over and around obstructions. Higher-frequency radio waves do not behave in this manner and are greatly weakened by substantial obstructions or the absence of a direct path. Simply put, all antennas communicating with each other in the radio network must be able to physically **see** each other.

For this reason, a proper antenna site must meet the following criteria:

1. For optimum performance at maximum range, there must be a clear line-of-sight path among all antennas that communicate directly with each other. At shorter ranges, some degree of obstruction may be tolerated, but performance in the presence of obstruction is difficult to predict.
2. Elevating one or more of the antennas in the system increases maximum line-of-sight range, called the radio horizon. If antennas are located at a greater range than the ground-level radio horizon, a means must be available for elevating the antennas.
3. All antennas must be properly oriented, and a directional antenna must be carefully aimed at its target antenna to ensure communication at maximum range.
4. All antenna cables *attenuate* (reduce) signal strength in proportion to their length. Therefore, the distance between the antenna and the radio is limited to a cable length that does not exceed the maximum attenuation tolerated by the system. Since various cable types offer different attenuation levels, maximum length depends on cable type. Generally speaking, because the *VIP 110-24* is an outdoor unit with the output port connected directly to the antenna, cable losses are

negligible and the radio will compensate, but there are limits to this compensation. See table 5-2 for sample cables and their respective attenuation values.

Each of these criteria is discussed at greater length in the following paragraphs.

### 5.3.1 Line-of-Sight Path

Because high-frequency radio waves are attenuated by obstructions, a clear line-of-sight path between antennas is required for optimum performance at maximum range. For shorter ranges, a degree of obstruction may be acceptable. For example, at less than maximum ranges the radio has some ability to penetrate trees and other foliage. On the other hand, geographical features (hills) and large buildings are likely to interfere with communications, and antennas must be elevated to see each other above such objects.

Because of the uncertainties of radio communication, it is difficult to predict the results in conditions where obstructions exist. The only valid advice is to try the proposed configuration and be prepared to move or elevate the antennas.

### 5.3.2 Radio Horizon (Maximum Line-of-Sight Range)

In visual terms, the horizon is the point in the distance where an object drops out of sight because it is blocked by the earth's curvature. If the observer or object is elevated, the visual horizon is extended, that is, the object can be seen at a greater distance before it drops out of view.

The same concept applies to radio signals. The radio horizon is the point in the distance where the path between two antennas is blocked by the curvature of the earth. Like the visual horizon, the radio horizon can be extended by elevating the transmitting antenna, receiving antenna, or both to extend communication range.

The radio horizon can also be extended or shortened by certain phenomena such as refraction due to atmospheric density and temperature inversions. Fog and rain, which reduce signal strength, can also shorten the radio horizon although in the ISM band, this loss is negligible.

A reasonable approximation of the radio horizon based on antenna height can be obtained from the graph in figure 5-1. **Note that this graph does not take atmospheric effects into account.** To use the graph, set a straight edge so that it crosses the height of one of the antennas in the column on the left and the height of the other antenna in the column on the right. The radio horizon in miles/km is shown where the straight edge crosses the center column.

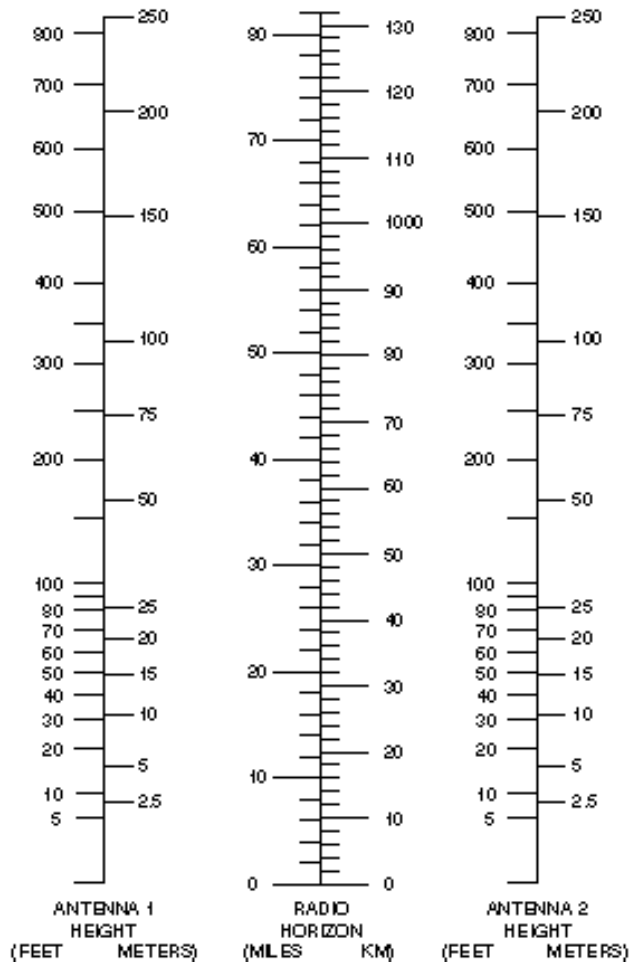

Figure 5-1. Antenna Height and Radio Horizon Graph

If the radio horizon is well within maximum communication range of the system, this graph provides a reasonable guide for antenna height. However, as maximum range of the system is approached, results are less reliable because of atmospheric effects and other unpredictable phenomena. In such cases, the more thorough point-to-point path analysis described in the next section should provide more reliable results.

### 5.3.3 Point-to-Point Path Analysis

A full point to point analysis should consist of at a minimum, a background noise evaluation of all locations where radios are to be installed, a determination of the minimum antenna height required to obtain a **line-of-sight**, and a calculation of the expected RSS level to be received at each of the locations. The background noise measurement is critical as it gives the operator a preview of the potential performance variations and the feasibility of utilizing a particular radio at a location. For example, if the background noise is found to be at the same level as the radio sensitivity (when set to

maximum speed), a tradeoff analysis can be conducted before installation to determine if lowering the data rate will allow the radio sufficient link margin to operate. A line-of-sight is required to ensure the best performance from the radio. The calculations below will allow the operator to build towers and other mounting areas to the correct height before the antennas are installed. The calculation of the RSS level is useful for two purposes. The first and primary purpose is to calculate the theoretical RSS level at the receive radio to determine the link margin at the site. This information, when coupled with the background noise measurement, will tell the operator if a link can be established and give a reasonable **a priori** estimate of the performance of the system. In addition to this, the RSS level allows the operator to do a quick check on the integrity of the system installation by verifying that the received RSS level is close to the calculated value.

A background scan is easily accomplished using the built in Spectrum Analysis tool of the VIP 110-24. This should be done before any installation of any equipment is completed.

Although the graph of figure 5-1 provides a useful guide to antenna height requirements, a more accurate determination of those requirements can be obtained by means of the analysis described in the following steps.

### **NOTE**

Computer programs available from many vendors can perform portions of this procedure.

Requirements for this procedure are:

1. A topographical map of the installation site.
2. Graph paper, ten divisions per inch or equivalent metric scale
3. Straight edge
4. Calculator

Procedure:

1. On the topographic map, identify the precise location of each antenna site.
2. Draw a straight line between the sites; this line is the radio path.
3. On the graph paper, establish a vertical axis for elevation and a horizontal axis for distance. It is usually easiest to make the vertical axis in feet or meters and the horizontal axis in miles or kilometers.
4. Following the radio path line on the map, identify all obstructions. Most topographical maps identify geographic information, such as hills and lakes, only. However, vegetation, buildings or other structures that will interfere with radio transmissions must also be included.
5. Plot each obstruction on the graph, marking its elevation and distance from the sites. For dense vegetation such as forests, add 40 to 60 feet (12 to 18 m) to the ground elevation.

An additional increment must be added to the height of each obstruction because of the earth's curvature. For each obstruction calculate this increment using the following formula:

$$d = \frac{d1 \times d2 \times C}{K}$$

Where:

(for US units:)

d	=	additional height increment in feet
d1	=	distance of the obstruction from the first site in miles
d2	=	distance of the obstruction from the second site in miles
C	=	.667 for US units
K	=	refractive index (use a value of 1.33).

(or for metric units:)

d	=	additional height increment in meters
d1	=	distance of the obstruction from the first site in km
d2	=	distance of the obstruction from the second site in km
C	=	.079 for metric units
K	=	refractive index (use a value of 1.33).

Add the **d** value to the height of each obstruction plotted on the graph.

Another increment must be added to the height of each obstruction because of the **Fresnel** zone (The required increment is 60% of the first **Fresnel** zone radius). For each obstruction calculate the increment using the formula:

$$d = C \sqrt{\frac{d1 \times d2}{F \times D}}$$

Where:

(for US units:)

d	=	60% of the first Fresnel zone radius in feet
d1	=	distance of the obstruction from the first site in miles
d2	=	distance of the obstruction from the second site in miles
C	=	1368 for US units
F	=	2400 (frequency in MHz)
D	=	total path length in miles (d1 + d2).

(or for metric units:)

d	=	60% of the first Fresnel zone radius in meters
d1	=	distance of the obstruction from the first site in km
d2	=	distance of the obstruction from the second site in km
C	=	259 for metric units
F	=	2400 (frequency in MHz)
D	=	total path length in km (d1 + d2).

Add the **d** value to the height of each obstruction plotted on the graph.

Determine ideal antenna height by drawing a line on the graph between the sites and across the top of the obstruction heights. Note the elevation at each antenna site.

The following section will show how to calculate the RSS level expected at the radio and to determine the theoretical link margin at the sight.

Determine free-space path loss, using either table 5-1, the graph of figure 5-2, or the formula following figure 5-2.

**Table 5-1. Free-Space Path Loss at 2.4 GHz**

Distance (miles)	Path Loss (dB)	Distance (km)	Path Loss (dB)
1	-104	1	-100
2	-110	2	-106
3	-114	3	-110
4	-116	4	-112
5	-118	5	-114
6	-120	6	-116
7	-121	7	-117
8	-122	8	-118
9	-123	9	-119
10	-124	10	-120
11	-125	15	-124
12	-126	20	-126
13	-126	25	-128
14	-127	30	-130
15	-128	35	-131
20	-130	40	-132
25	-132	45	-133
30	-134	50	-134
35	-135	55	-135
40	-136	60	-136
45	-137	70	-137
50	-138	80	-138

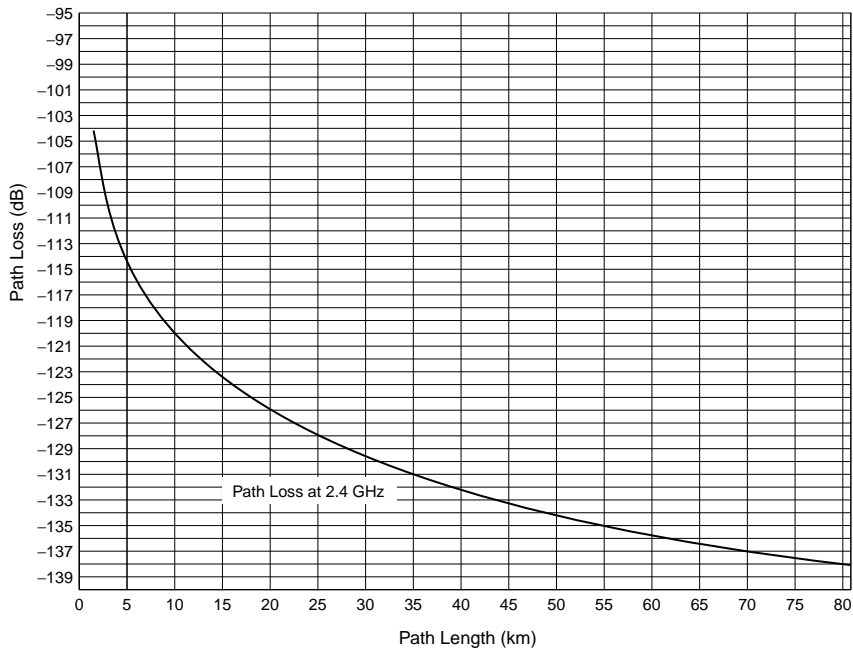
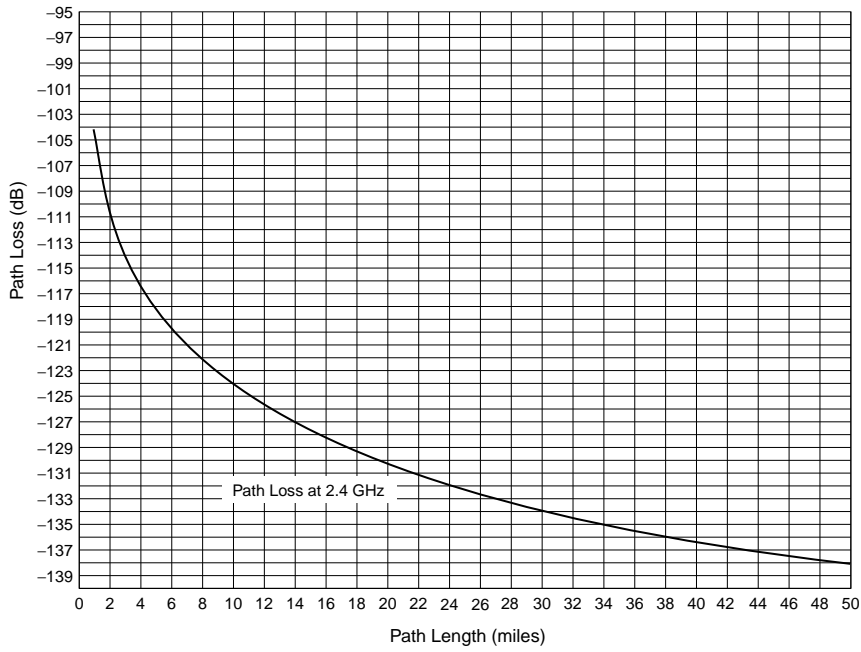

Figure 5-2. Free-Space Path Loss at 2.4 GHz

$$-L = C + 20 \log(D) + 20 \log(F)$$

Where:

(for US units)

<b>-L</b>	=	loss in dB
<b>C</b>	=	6.6 for US units
<b>D</b>	=	path length in miles
<b>F</b>	=	2400 (frequency in MHz)

(or for metric units)

<b>-L</b>	=	loss in dB
<b>C</b>	=	32.5 for metric units
<b>D</b>	=	path length in km
<b>F</b>	=	2400 (frequency in MHz)

For example, for a distance of 10 miles

$$-L = 36.6 + 20(1) + 20(3.38)$$

$$-L = -124 \text{ dB}$$

Calculate **Effective Radiated Power** (ERP) at the transmit antenna. Since the VIP 110-24 is housed in an outdoor enclosure, there is usually no transmission line loss as the antenna is generally connected directly to the radio connector. However, if an additional cable is used between the radio and the antenna cable, the cable loss (attenuation) must be included in order to calculate the correct RSS level.

VIP 110-24 output power	=	+ 23 dBm
Cable attenuation	=	- 2 dB
Transmit antenna gain	=	+ 17 dB
Effective Output Power	=	<u>+ 38 dBm</u>

NOTE: Table 4.2 lists attenuation values for various cables.

Calculate the RSS level at the receive radio using the formula:

$$\text{RSS} = P_t - L_p + G_r$$

Where:

<b>P<sub>t</sub></b>	=	Output power from the transmit antenna
<b>L<sub>p</sub></b>	=	path loss
<b>G<sub>r</sub></b>	=	Gain of the receive antenna

For example, for the above system at a distance of 10 miles, with transmit output power of 38 dBm, and a receive antenna gain of 24 dB, the equation would be:

$$\begin{aligned} \text{RSS} &= 38 \text{ dBm} - 124 \text{ dB} + 24 \text{ dB} \\ &= -62 \text{ dBm} \end{aligned}$$

Calculate link margin by subtracting radio sensitivity from the calculated RSS level.

Calculated RSS level at receiver	=	-62 dBm
Sensitivity of 2411 at 11 Mbps	=	-81 dB
link margin	=	<div style="border-top: 1px solid black; display: inline-block; width: 100px;"></div> +19 dB

This figure, **link margin**, is the amount of signal received by the radio that is above the minimum required for the radio to meet its performance characteristics. This value is important since it gives the operator an indication of how much **signal fade** the system can tolerate. Signal fading may be caused by multiple radio paths (reflections) atmospheric conditions such as rain, temperature inversions, fog, etc., and may last anywhere from a few moments to several hours and cause as much as 20 to 30 dB of signal strength loss. Although it is possible to operate a system with a link margin as low as 5 dB, as general rule of thumb it is recommended that all systems have a link margin of better than 20 dB.

#### 5.3.4 Antenna Orientation

Antennas at each end of a communications link must be mounted similarly in terms of polarity, and directional antennas must be carefully oriented towards each other. The choice of polarization – horizontal vs. vertical – is in many cases arbitrary. However, interfering signals from such devices as cellular phones and pagers are generally polarized vertically, and an excellent means of reducing their effect is to mount system antennas for horizontal polarization. Of those antennas in section 5.2 for *VIP 110-24* systems, the directional antennas can be mounted for horizontal or vertical polarization, while the omnidirectional antennas use only vertical polarization. Horizontally polarized omnidirectional antennas are available as a special purchase.

Orientation of directional antennas is critical because their sensitivity is greatly reduced outside a fairly narrow angle. Performance of the system can be seriously degraded by mis-aligned directional antennas. The *VIP 110-24* has a built in feature that allows the operator to use a tone to assist in aligning the antenna. Refer to chapter 6 on the use of this built-in antenna alignment feature.

#### 5.3.5 Cable Loss (Attenuation)

The *VIP 110-24* is housed in a watertight IP66 rated enclosure so that it may be mounted in very close proximity to the antenna. Using short cables to connect the radio to the antenna reduces signal losses. Table 5.2 shows loss per 100 feet (30 meters) at 2.4 GHz for typical antenna cable types.

**Table 5-2. Loss at 2.4 GHz for Standard Coaxial Cable Types**

<b>Cable Type</b>	<b>Loss per 100 ft. (30 m)</b>
RG-8 A/U	14.4 dB
Belden 9913	8.0 dB
LMR 195	19 dB
LMR 400	6.7 dB

To determine total cable loss for your installation, perform the following calculation:

For US units, multiply length in feet by the loss figure and divide by 100.

For metric units, multiply length in meters by the loss figure and divide by 30.

For example, for a 75-foot length of Belden 9913, the loss is:

$$\frac{75 \times 8.0}{100} = 6.0 \text{ dB}$$

### 5.3.6 Connector Loss

Loss is introduced with each pair of cable connectors. Attenuation losses of some standard cable types are shown in the following table:

Connector type	Loss per connector
N-Type	0.25 dB
SMA-Type	0.25 dB

The loss of each pair of connectors on all cables must be included to determine the total signal loss (attenuation) between the antenna and ODU.

### 5.3.7 Other Considerations – Antenna Grounding



#### **VERY IMPORTANT INFORMATION**

As an elevated metal object with a wire connection below, an antenna is an excellent lightning attractor, and an effective ground must be provided to deflect lightning strikes to ground. An additional advantage of effective system grounding is the minimizing of electrical noise and interference, which can significantly degrade system performance.

Grounding involves providing a good, very low resistance connection from the antenna and radio to earth ground to provide a better path for lightning and electrical noise than that through the equipment. The following points should be taken into account in setting up system grounding:

- The antenna and radio should be mounted on a mast or tower that is well grounded to earth.
- All antenna lead connectors should be correctly installed to provide a good, solid connection to the cable shield.
- Threaded couplings mating antenna lead connectors should be clean and tight; bayonet type connectors should not be used.
- Weatherproof connectors must be used for outdoor connections to prevent corrosion, which will interfere with grounding.
- All power and antenna grounds should be made common at a single point such as an equipment rack, cabinet enclosure chassis, or antenna tower. This single-point ground should have a solid ground connection to earth.
- If the unit is installed indoors, a surge arrestor or lightning protector should be installed at the point where the antenna cable enters the building or cabinet. The lightning protector should be properly grounded at the single-point chassis ground. Carefully follow the installation instructions provided by the manufacturer of the protection device. Appropriate lightning protectors are available from EION Inc.

## 6 INSTALLATION AND SETUP

The VIP 110-24 units are shipped pre-configured to operate as **repeaters**. It is recommended that an initial check be performed on the bench before a field installation.

For this bench check out you need two VIP 110-24 units. One of the radios will be configured as the **root** of the network and the other as a **repeater**. The first approach, described below, uses the **Ethernet Console Program** to emulate the terminal across an Ethernet connection. The second approach uses two terminals connected to the auxiliary port of the radios. Since the radio are to be mounted close to the antenna and the use of the serial port will be inconvenient, EION recommends the use of telnet or the Ethernet console program to communicate with and configure the radios.

### 6.1 Bench Check Out (using radio Ethernet connection)

The VIP 110-24 can be accessed via the Ethernet port by one of two methods. The primary method is via **telnet**. If telnet is to be used, then follow the procedure below up to step 5, then go to Section 8.1 to initiate a telnet session. Once the session has been established, start the below procedure again at step 7.

The secondary method is to use the **Ethernet Console Program (Econsole)**. Once Econsole is installed, perform the following steps.

1. Connect the PC Ethernet port to the **To LAN** connector of the **Power Inserter Unit** of the repeater radio. Use an Ethernet crossover cable if connecting the PC directly to the Power Inserter Unit, or use a straight cable if connecting through a hub.
2. Connect each Power Inserter Unit to the respective VIP 110-24 using a CAT 5 cable as defined in section 2.
3. At the **root** radio connect the radio Antenna B port (N type connector) to an appropriate 2.4 GHz band antenna using an RF coaxial cable.
4. At the **repeater** radio connect the radio Antenna A port to an appropriate 2.4 GHz band antenna using an RF coaxial cable.
5. Connect the two Power Inserter Units to a power outlet. Make sure that the power supplies are rated for the appropriate voltage (110 or 220 Volts AC).
6. On the PC, open a DOS window and invoke the Econsole program by typing:  
    > econ  
    If only one radio is connected to the LAN, Econsole will establish a connection with that radio. If more than one radio are in the same LAN Econsole provides a list of all radios found (see Appendix E for more detailed instructions on the use of Econsole). Once a connection to the radio is established, the radio outputs the prompt:  
        EION-nnnnn #>  
    where *nnnnn* are the last five digits of the radio serial number (if the radio had previously been configured the prompt will be the radio **name**).
7. Set the **repeater** VIP 110-24 to its factory default configuration by typing the commands:

```

load factory
> save-configuration
> logout

```

8. Move the Ethernet cable from the repeater power inserter to the power inserter connected to the root radio. At the DOS window invoke once again the Econsole program. Configure the second radio (defined as the **root**) by typing the commands:

```

> load factory
> node type=root
> ip addr=192.168.1.101

```

*Note: If you are connected via telnet when you change the IP address, the connection will be lost at this point. You must start a new telnet session using the new IP address.*

```

> save-configuration

```

9. Once a radio is configured as the **root** it will establish a RF communication with the second radio. To verify this connection type:

```

> show radio-node

```

Verify that the two radios are listed with the correct serial numbers. The output also displays the transmit RF power and Receive Signal Strength (RSSI) in both link directions.

10. Once the link is established, Telnet or Econsole can be used to configure the local and/or the remote radio. In order to switch a telnet session, logout of the current connection and telnet to a different radio:

```

> logout

```

Section 7 describes the command language used to further modify the radio's operating parameters.

11. In order to switch a Econsole session, logout of the current connection and re-invoke Econsole:

```

> logout
> econ

```

Econsole will list the two radios and give a choice to connect to either. Section 7 describes the command language used to further modify the radio's operating parameters.

## 6.2 Bench Check Out (using radio auxiliary ports)

1. Connect each VIP 110-24 Auxiliary Port to a terminal, or a PC running a terminal emulation program. Configure the terminal settings as follows:
  - Baud rate: 9600
  - Word length: 8 bits
  - Parity: none
  - Stop bits: 1
2. Connect each Power Inserter Unit to the respective VIP 110-24 using a CAT 5 cable as defined in section 2.

3. At the root radio connect the radio Antenna B port (N type connector) to an appropriate 2.4 GHz band antenna using an RF coaxial cable.
4. At the repeater radio connect the radio Antenna A port to an appropriate 2.4 GHz band antenna using an RF coaxial cable.
5. Connect the two Power Inserter Units to a power outlet. Make sure that the power supplies are rated for the appropriate voltage (110 or 220 Vac).
6. The radios will perform power up calibration and diagnostic tests. Verify that radios identify themselves with the correct serial number. At the end of the tests, the radios output the command prompt:

```
EION-nnnnn #>
```

where nnnnn are the last five digits of the radio serial number.

7. Set the "repeater" VIP 110-24 to its factory default configuration by typing the command:

```
> load factory
> save-configuration
```

8. Configure the second radio (defined as the "root") by typing the commands:

```
> load factory
> node type=root
> save-configuration
```

9. At the terminal connected to the repeater radio enter the command:

```
> show radio-node
```

Verify that the root node is listed with the correct serial number. The output also displays the transmit RF power and Receive Signal Strength (RSSI) in both link directions.

10. The terminal connected to each radio can be used to further modify the radio's operating parameters. Section 6 describes the command language used to perform those functions.

## 6.3 Field Installation

### **NOTICE**

The antennas for the *VIP 110-24* must be professionally installed on permanent structures for outdoor operations. The installer is responsible for ensuring that the limits imposed by the applicable regulatory agency (Federal Communications Commission, FCC, or CE) with regard to Maximum Effective Isotropic Radiated Power (EIRP) and Maximum Permissible Exposure (MPE) are not violated. These limits are described in the following sections.

#### 6.3.1 Antenna Installation

The *VIP 110-24* is typically attached to a pole (with the clamp provided) with the antenna connectors facing up. For optimum performance the radio must be mounted in close proximity to the antenna with a cable run typically under 2 meters (6 feet). For a list of antennas suitable for the *VIP 110-24*, see **Section 5.2 Selecting Antenna Type**.

Antennas at each end of the link must be mounted such that they have the same polarization, and directional antennas must be carefully oriented towards each other. The choice of polarization (horizontal vs. vertical) is, in many cases, arbitrary. However, many potentially interfering signals are polarized vertically and an excellent means of reducing their effect is to mount the system antennas for horizontal polarization.

Directional antennas can be mounted for horizontal or vertical polarization, while the omnidirectional antennas can only be mounted for vertical polarization. Horizontally polarized omnidirectional antennas are available upon special request.

Proper grounding of the antenna is important for lightning protection as well as to prevent electrical noise interference from other sources. The antenna should be mounted to a mast or tower that is well grounded to Earth. Use threaded connectors to mate to the antenna lead connectors and check that all connectors are clean and tight. Use weatherproof connectors in all outdoor couplings. We recommend using “rubber mastic tape” like Scotch 2228 from 3M to further weatherproof outdoor connections.

In locations where it is warranted, install lightning protectors at the N type connectors leading to the antennas. You may also want to install a surge arrester/lightning protection on the Ethernet cable where it connects to the equipment rack. The lightning protectors should be properly grounded. Carefully follow the installation instructions provided by the manufacturer of the lightning protection device used.

#### 6.3.2 Antenna Alignment

When mounting the high gain antenna (24 dBi), the proper antenna alignment is extremely important since the beam-width of the antenna is very narrow. Once you perform a rough alignment and the link is in operation, you can use the “monitor-link” and “antenna-alignment-aid” commands to fine tune the alignment. Before using those commands type:

> **show**

to list the existing links and identify the remote radio number that you want to align the antenna to. In a typical VINE network, the high gain antenna is on port A pointing at the parent. In this case the

parent is always radio #3. However you can also use these tools to align antenna B to point to any specific child.

Once you know the remote radio number (N) type the command:

> **monitor-link #N**

in order to update, every half second, the link statistics including the RSSI level at both ends of the link. The antenna can then be aligned so that the RSSI is maximized.

Since in many applications the antenna is on a tower where it is not practical to have a terminal nearby, the *VIP 110-24* has an additional "antenna alignment aid" available at the outdoor unit. This feature uses the three pin "Auxiliary port" connector to output an audio signal with a pitch proportional to the receive signal strength. EION provides a special cable adapter that converts the three-pin connector into a standard female audio jack. Use this cable to connect the three-pin connector to a pair of standard headphones while aligning the antenna. At a terminal session issue the command:

>**aaa audio #3** (aaa is an abbreviation for "antenna-alignment-aid")  
and then align the antenna until you hear the highest audio pitch.

Once the antenna is aligned you may type the command:

>**aaa off**

to turn off the audio signal and revert the auxiliary port connector to console mode.

**Note:** if the audio antenna alignment feature is enabled while a terminal is connected to the serial port, random characters will be continually printed to the display. Access to the unit is still possible but the output will not be readable. If a leaf is configured for RF Plug and Play, the audio antenna alignment feature will be enabled automatically.

### 6.3.3 Spectrum Analysis and channel selection

Radio operation in unlicensed bands has the potential of suffering from interference from other equipment operating in the same band. The use of directive antennas (used for the upstream connection), greatly reduces the potential for interference. In addition, the *VIP 110-24* includes several features, described below, to identify and overcome sources of interference.

The *VIP 110-24* can be commanded to perform a spectrum analysis of the ISM band and report the results in either a graphical or tabular form. The command:

>**spectrum-analysis input=a-antenna dwell=xx**

instructs the radio to scan the entire band, dwelling on each channel for a programmable amount of time, and record the highest signal level in that channel. This feature can be used to perform a site survey and identify the best receive channel for the specific link.

Note that even though the *VIP 110-24* channels are spaced 2 MHz apart, the receiver RF bandwidth is approximately 18 MHz. Therefore the RSSI value reported for each channel represents the total energy in an 18 MHz band centered around that channel. For this reason, a narrow band transmitter will show up in the spectrum analysis report as a lobe with 18 MHz bandwidth. Conversely, you do not need to find a quiet 18 MHz wide region in the spectrum analysis report to select a quiet channel, i.e., any single channel sample that shows a low "noise" level, is a good candidate to select a receive channel.

Once a potential receive channel has been identified using the spectrum analysis tool, a “timing analysis” may also be used to confirm that the selected channel is indeed clear. The command:

**>time-analysis channel=xx input=a-antenna dwell=xx**

instructs the radio to dwell on the specified channel for the specified amount of time. After taking several samples the radio displays the signal level detected in that channel over time.

At installation time you may also want to use the command:

**>monitor-environment**

This command sets the radio in receive only mode dwelling consecutively in each of the channels shown in the “display configuration” report. For each packet received the radio identifies its source and whether the packet is a “new node poll” (NNP) or otherwise. Among all the sources that broadcast new node polls in the “rf-from-parent” channel, the radio identifies the one with the strongest signal. This is indicated with the “>>” characters in the left column of the report. When the monitor environment mode is exited (by depressing any key), the radio will first attempt to attach to that potential parent. Refer to section 6 for more details about this command.

#### 6.3.4 Output Power Limits (FCC)

The Federal Communications Commission (FCC) regulations limit the maximum Effective Isotropic Radiated Power (EIRP) for spread spectrum systems operating in the 2.4 GHz band. Close to the band edges, the output power must be limited to avoid spilling over into the FCC protected band from 2.4835 GHz to 2.500 GHz. The table below takes these considerations into account and shows the maximum allowed output power for the various antennas

**Maximum Output Power (dBm)**

Channel (#)	Frequency (MHz)	Antenna Gain		
		9 dBi	17 dBi	24 dBi
5	2410.0	23	22	21
6	2412.0	23	23	22
7	2414.0	23	23	22
8	2416.0	23	23	22
9	2418.0	23	23	22
10 to 30		23	23	23
31	2462.0	23	22	22
32	2464.0	23	20	19
33	2466.0	21	18	17
34	2468.0	20	17	16
35	2470.0	20	17	15

**6.3.5 Output Power Limits (CE)**

The European Telecommunications Standards Institute (ETSI) regulations impose a limit of 20 dBm as the maximum Effective Isotropic Radiated Power (EIRP) for direct sequence spread spectrum systems operating in the 2.4 GHz band. The installer must reduce the output power of the *VIP 110-24* so that this limit is not exceeded. The antenna gain, cable and connector losses must be taken into account when computing the maximum output power.

**6.3.6 Maximum Permissible Exposure (MPE) Limitations**

The installer must mount all transmit antennas so as to comply with the limits for human exposure to radio frequency (RF) fields per paragraph 1.1307 of the FCC Regulations. The FCC requirements incorporate limits for Maximum Permissible Exposure (MPE) in terms of electric field strength, magnetic field strength, and power density.

Antenna installations must be engineered so that MPE is limited to 1 mW/cm<sup>2</sup>, the more stringent limit for "uncontrolled environments". The table below specifies the minimum distance that must be maintained between the antenna and any areas where persons may have access, including rooftop walkways, sidewalks, as well as through windows and other RF-transparent areas behind which persons may be located.

**Minimum Distance calculation to  
avoid Antenna Radiation Hazard (exposure of 1 mW/cm<sup>2</sup>)**

<b>Antenna Gain (dBi):</b>	<b>9</b>	<b>17</b>	<b>24</b>
<b>Max. Output Power</b>	23	23	23
<b>MPE safe distance (cm)</b>	11*	28*	63*

**\*NOTE: For fixed location transmitters, the minimum separation distance is 2 m, even if calculations indicate a lower MPE distance.**

### 6.3.7 Installing a Leaf Using RF Plug and Play

3. Power up the Leaf and connect a headset to a serial port.
4. Point the antenna in the general direction of a Parent (Root or Repeater.)

You will hear a continuous loop of a ping and a long pause as the Leaf is looking for a Parent. When the Leaf finds a potential Parent, the tone changes to a loop of a ping and a short pause. If the Leaf attaches to a Parent, the tone changes to a 2-tone warble. If you don't hear a 2-tone warble in 120 seconds (2 minutes), power off the Leaf and return to Step 1.

5. When the 2-tone warble stops, listen for a steady tone.

If you don't hear a steady tone within 120 seconds (2 minutes), there are no available Parents, or the antenna is not pointed toward a Parent. Rotate the antenna until you hear a steady tone.

6. When you hear the steady tone, adjust the antenna a few degrees to the left and right, and listen for the highest pitched steady tone.

The highest pitched tone has the strongest RSSI signal and will provide the strongest link between the Leaf and the Parent.

While adjusting the antenna, you will also hear a 3-tone burst of increasing pitch as the fade margin exceeds the link margin, and a 3-tone burst of decreasing pitch as the fade margin drops below the link margin. Continue to adjust the antenna until you find the highest pitched tone.

7. When you have found the highest pitch tone, the Leaf has located the Parent that will provide the best performance. Stop and lock the antenna.

If the Leaf stops all tones, it was unable to attach to a Root. Cycle the power and wait for the Leaf to successfully attach.

If you don't hear a steady tone, continue to rotate the antenna 360°. If you cannot get a tone in any direction, replace the Leaf and repeat the procedure.

If you still don't hear a tone, contact the network administrator.

**Tones Pings and Pauses**

<b>Tone or Pause</b>	<b>Description</b>
short ping, long pause	Leaf is scanning for a Parent
short ping, short pause	Leaf has found a possible Parent
2-tone warble	Leaf is attaching to a Parent
steady tone	Leaf has successfully attached to a Parent
3-tone burst of increasing pitch	RSSI minus the BER point exceeds Link Margin
3-tone burst of decreasing pitch	RSSI minus the BER point drops below Link Margin
no tone	Leaf is unable to attach to a Parent

**6.4 Upgrading the Firmware.****6.4.1 Description**

The operational firmware for the *VIP 110-24* is stored in Flash PROM and can be easily updated. The Flash PROM can hold multiple versions of the firmware simultaneously. The table below lists some of the “File Utility” commands used to download and manage the various files stored in Flash PROM. A more detailed explanation for each command can be found in section 6.

**File Utility command summary**

<b>Command</b>	<b>Description</b>
directory	Lists all files stored in Flash PROM
delete-file filename	deletes the specified file from the directory
download-file path/filename	downloads the specified file from the PC path/filename into the Flash PROM
set-default-program filename	Sets the indicated filename as the default program to run after power up
run-file filename	loads the indicated program into RAM and executes it.

New firmware versions are made available from time to time at the EION Wireless website in the “support” section:

<http://www.eionwireless.com>

The firmware files are named:

vipNN-NN-NN.bin	(binary file for downloads through the Ethernet port)
vipNN-NN-NN.bz	(compressed binary file for downloads through the Ethernet port)
vipNN-NN-NN.dwn	(ascii file for download through the serial port, or via Telnet)

where NN-NN-NN is the firmware version number. The website contains instructions for transferring the files into your PC.

A new file can be downloaded into the radios in one of three ways: (1) Using the “econ” program running in a PC connected to the same physical LAN as one of the radios in a VINE network. This is the fastest method and allows you to download to every radio in the VINE from the same PC. (2) Using a Telnet session from anywhere on the Internet. This requires the radio to have been pre-configured with an IP address. (3) Using a terminal emulator program (e.g. HyperTerminal) running on a PC connected through the serial port to the radio RS-232 auxiliary port. This method only allows you to download to that specific radio.

The next three sessions explain in detail how to download a new file using each method.

#### 6.4.2 Installing new firmware through the Ethernet port

This procedure assumes that the new firmware needs to be installed in all radios of a working VINE network. The upgrade is performed from a single PC connected via Ethernet to any one of the radios in the network. Note that new firmware does not need to be compatible with the firmware currently running. You can still download incompatible firmware and restart the whole network from a single location.

1. If you have not done so, install the utility program “econ” in the PC. This utility program is distributed with the radios and can also be downloaded from the website. Please refer to appendix E for instructions on how to install this utility.
2. Make sure the file with the new firmware (file vipNN-NN-NN.bin or vipNN-NN-NN.bz) is available in the PC.
3. Start the econsole utility by typing “econ” from a DOS window. Verify that the econ version is 1.06 or greater (if not download the latest version from the website). Econ will send a “discovery” message and display all the radios that can be seen. Verify that all radios in the network are listed. Then select one of the radios to log-on to that particular radio.
4. Issue the command:  
**>version**  
 If the radio firmware version is 1.03, you must use the instructions found on Application Note 137. This application note can be found in the support section of our web site at: [www.eionwireless.com](http://www.eionwireless.com). For version 1.04 or higher proceed as follows.
5. Issue the command:  
**>directory**  
 to view a list of files stored in Flash PROM as well as the available free space. Verify that the free space in flash PROM is larger than the size of the vipNN-NN-NN.bin or vipNN-NN-NN.bz file in the PC. If there is not enough space in Flash PROM delete one of the program files to make up space (use command >delete filename).

6. If the radio configuration has been password protected, you must first unlock the protection with the command:

**>unlock enable-configuration=*password***

(when the configuration is unlocked, the radio prompt ends with the characters '#>'. In locked mode the prompt does not include the '#' character).

7. Issue the command:

**>download *path/vipNN-NN-NN.bin***

or

**>download *path/vipNN-NN-NN.bz***

where *path/* is the directory in the PC where the *vipNN-NN-NN.bin* or *vipNN-NN-NN.bz* file is stored. The *path/* extension is not required if the file is in the same directory as the ECON program. As the download proceeds econ displays a line showing the current percentage complete.

8. Once the download is complete, issue the command:

**>set-default-program *vipNN-NN-NN***

in order to make the new file the default program to run after a reset.

9. Issue the command:

**>single-node-reboot-timeout 60**

in order to speed up the network recovery after rebooting the root node below (this step is not necessary if the new firmware is known to be compatible with the old one but it does not hurt in either case).

10. Depress the "F4" key ("F6" for Econ versions 1.05 and 1.06) to log-off the session with the current radio. "Econ" displays the list of all radios from the initial discovery phase. Select the next radio and repeat steps 4 through 9.

11. Once all radios in the network have the new program, log onto the root radio (using econsole) and issue the command:

**>reboot**

to cause the root radio to restart using the new firmware.

12. If the new firmware is compatible with the old one, all radios will reattach to the root in a short time (with the root running the new version and all other radios running the old version).

If the new firmware is incompatible with the old one, the non-root radios may not attach to the root. In this case, after 60 seconds, the non-root radios that did not reattach will reboot. Those radios will now execute the new firmware and be able to attach to the root. In either case the whole network should be back up and running in less than two minutes.

13. After waiting an appropriate amount of time press <CR>. Econsole automatically attempts to reconnect to the root radio. Once a new session with that radio is reopened issue the command:

**>version**

and check that the root radio is indeed executing the new version. Then issue the command:

**>show**

to verify that all nodes in the network have reattached.

14. Depress the “**F4**” key (“**F6**” for Econ versions 1.05 and 1.06) to log-off the session with the current radio. “Econ” displays the list of all radios from the initial discovery phase. Select a different radio and issue the command:  
**>version**  
 and check if that radio is running the new or old version. If the radio is already running the new version repeat this step with the next radio. Otherwise perform the next step.
15. If the radio is running the old version issue the command:  
**>reboot**  
 Wait a few seconds for the radio to perform its start up code and reattach to the network. Then press <CR>. Econ console automatically attempts to reconnect to the same radio again. Once a new session with that radio is reopened issue the command:  
**> version**  
 and check that the radio is indeed executing the new version.
16. Repeat the previous two steps until all the radios are running the new firmware.

Note that the file downloads are executed with the network in full operation. The only downtime in the network occurs when the radios are rebooting. The radio configuration is kept intact when a new version is started. The downtime for the radio being restarted, and all its children, is typically less than twenty seconds. When upgrading to an incompatible version, the downtime will be less than two minutes.

#### 6.4.3 Installing new firmware using FTP

File Transfer Protocol (FTP) is a protocol that allows you to access a remote radio from a local host. You must know the IP address of the radio, and it must be reachable, over the network, from the local host. A new VIP will have the default IP address of 192.168.1.100. Refer to section 8 for details on how to initiate an FTP session.

1. Make sure the file with the new firmware (file vipNN-NN-NN.bin or vipNN-NN-NN.bz) is available in the PC. If FTP is to be started from a DOS prompt, it is best to initiate the session in the same directory where the files to be uploaded are located.
2. Start the FTP session as described in section 8. Make sure the local machine has the correct SNMP manager address and that you know the SNMP community and configuration password.
3. Issue the command:  
**>cd flash**  
 in order to get to the flash directory of the radio.
4. Issue the command:  
**>directory**  
 to view a list of files stored in Flash PROM as well as the available free space. Verify that the free space in flash PROM is larger than the size of the vipNN-NN-NN.bin or vipNN-NN-NN.bz file in the PC. If there is not enough space in Flash PROM delete one of the program files to make up space (use command “delete <filename>”). If desired, issue the command “hash” so file transfers can be seen real-time.
5. Issue the command:  
**>put path/vipNN-NN-NN.bin**

or

**>put *path/vipNN-NN-NN.bz***

where *path/* is the directory in the PC where the vipNN-NN-NN.bin or vipNN-NN-NN.bz file is stored. The *path/* extension is not required if the file is in the same directory where the FTP session was initiated. If the command "hash" was sent previously, a series of "#" signs will indicate the upload process.

6. Once the download is complete, issue the command:  
**>bye**  
to close the FTP session.
7. Telnet to the radio following the instructions found in section 8.
8. If the radio configuration has been password protected, you must first unlock the protection with the command:  
**>unlock enable-configuration=*password***  
(when the configuration is unlocked, the radio prompt ends with the characters '#>'. In locked mode the prompt does not include the '#' character).
9. Issue the command:  
**>directory**  
to view a list of files stored in Flash PROM. Verify that the firmware is loaded into the radio.
10. Issue the command:  
**>set-default-program filename=vipNN-NN-NN**  
where NN\_NN file is new version of software being installed.
11. Issue the command:  
**>reboot**  
to restart the radio with the new software. Close the Telnet session, wait a few seconds and open a new session with the same radio.
12. Issue the command:  
**>version**  
to insure the radio is running the latest version.

Repeat the proceeding steps until all the radios are running the new firmware.

Note that the file downloads are executed with the network in full operation. The only downtime in the network occurs when the radios are rebooting. The radio configuration is kept intact when a new version is started. The downtime for the radio being restarted, and all its children, is typically less than twenty seconds. When upgrading to an incompatible version, the downtime will be less than two minutes.

When performing a system wide upgrade, it is important to ensure you perform the upgrade process from most remote link/leaf and work your way backwards through any repeaters and finally ending at the root.

#### 6.4.4 Installing new firmware using Telnet

Telnet is a protocol that allows you to conduct a remote radio command session from a local host. You must know the IP address of the radio, and it must be reachable, over the network, from the local host. A new VIP will have the default IP address of 192.168.1.100. Refer to section 8 for details on how to configure the radio IP address, change it from the default, and initiate a Telnet session. The Telnet terminal emulation must have the capability of sending an ASCII file to the remote machine. The following description assumes you are using Hyperterminal as the local Telnet terminal emulation.

1. Verify that the new software is available in the local machine. The download software for upgrade via Telnet must have a “.dwn” extension, e.g., vip02-60-01.dwn.
2. If the radio configuration has been password protected, you must first unlock the protection with the command:  
**>unlock enable-configuration=password**  
 (when the configuration is unlocked, the radio prompt ends with the characters ‘#>’. In locked mode the prompt does not include the ‘#’ character).
3. Issue the command:  
**>directory**  
 to view a list of files stored in Flash PROM as well as the available free space. Verify that there is enough free space in flash PROM for the new file. The space required will be the size of the vipNN-NN-NN.dwn file divided by 2.5. If there is not enough space in Flash PROM delete one of the program files to make up space (use command >delete filename).
4. Start the download process by typing:  
**>download-file destination=vipNN-NN-NN method=inline**  
 where NN-NN-NN file is new version of software being installed.
5. The radio will return with the following:  
*“Send the file ... if incomplete, end with a line with just a period”*  
 When you get this prompt, go to “Transfer-Send Text file...” in Hyperterminal and select the file to be installed. The file must have a “.dwn” extension.
6. After the file is successfully installed issue the command:  
**>directory**  
 to insure that the file has been loaded into memory.
7. Issue the command:  
**>set-default-program filename=vipNN-NN-NN**  
 where NN\_NN file is new version of software being installed.
8. Issue the command:  
**>reboot**  
 to restart the radio with the new software. Close the Telnet session, wait a few seconds and open a new session with the same radio.
9. Issue the command:  
**>version**  
 to insure the radio is running the latest version.

#### 6.4.5 Installing new firmware using the RS-232 serial port

On occasion, it may be necessary to install new firmware using the RS-232 port. This is generally a less desirable method as the download time is much longer and you can only update the radio that is directly connected to the PC, i.e., remote updates are not possible.

The serial upgrade uses a PC with a terminal emulator. Any emulator can be used, however, it must have the facility to download a text file on demand. In the example below, the emulator used is Windows Hyperterminal.

1. Connect the VIP 110-24 Auxiliary Port (3 pin circular connector) to a terminal, or a PC running a terminal emulation program. A special adapter cable is supplied by EION. Configure the terminal settings as follows:
  - Baud rate: 9600
  - Word length: 8 bits
  - Parity: none
  - Stop bits: 1
2. Verify that the new software is available in the PC. The download software for the serial upgrade must have a ".dwn" extension, e.g., vip02-60-01.dwn.
3. To have the shortest download time possible, set the radio to use the highest RS-232 speed allowable on the PC. In this example, a download speed of 57600 baud will be used. Set the console speed of the radio to 57600 baud by issuing the command:  
**>console-speed-bps 57600**
4. Change the baud rate of the PC to match the radio. Remember that with Hyperterminal, you must disconnect the session and re-connect before the changes will take effect. Verify the PC communicates with the radio again.
5. If the radio configuration has been password protected, you must first unlock the protection with the command:  
**>unlock enable-configuration=password**  
(when the configuration is unlocked, the radio prompt ends with the characters '#>'. In locked mode the prompt does not include the '#' character).
6. Issue the command:  
**>directory**  
to view a list of files stored in Flash PROM as well as the available free space. Verify that there is enough free space in flash PROM for the new file. The space required will be the size of the vipNN-NN-NN.dwn file divided by 2.5. If there is not enough space in Flash PROM delete one of the program files to make up space (use command >delete filename).
7. Start the download process by typing:  
**>download-file destination=vipNN-NN-NN method=inline**  
where NN-NN-NN file is new version of software being installed.
8. The radio will return with the following:  
*"Send the file ... if incomplete, end with a line with just a period"*  
When you get this prompt, go to "Transfer-Send Text file..." in Hyperterminal and select the file to be installed. The file must have a ".dwn" extension.

9. After the file is successfully installed issue the command:  
**>directory**  
 to insure that the file has been loaded into memory.
10. Issue the command:  
**>set-default-program filename=vipNN-NN-NN**  
 where NN-NN-NN file is new version of software being installed.
11. Issue the command:  
**>reboot**  
 to restart the radio with the new software. Remember to change the PC Hyperterminal settings back to 9600 baud and disconnect/re-connect the session.
12. Issue the command:  
**>version**  
 to insure the radio is running the latest version.

#### 6.4.6 Feature upgrades

The *VIP 100-24* has the ability to turn ON or OFF optional features and capabilities. This is done via the use of the "license" command. This command requires a "key" that is specific to a particular radio serial number and capability. To obtain a feature key, you must supply the specific model number, the serial number, and the feature desired. Please contact your local distributor for a list of optional features available for your radio.

Refer to Section 7.13 under "license" for the specific use of the license command.

## 6.5 Password Configuration and Recovery

### 6.5.1 Two-Tier Passwords

There are two modes that can log you into a radio. One mode enables you to make changes to radio parameters, the other mode allows you to view current radio parameters without making any changes.

The login name must be at least six characters long, but no more than 20 characters long, and can be a combination of any characters, either upper case or lower case with no white spaces.

To avoid potential data corruption, only one supervisor is able to remotely login at a time. However, access through the serial port is unrestricted (i.e. a supervisor may login through the serial port which a remote supervisor is logged-in)

### 6.5.2 Change Passwords

With the Change Password command, you can change or view radio parameters depending on the command you use.

To change or update radio parameters:

1. Log in to a unit.

2. At the prompt, enter  
***change-password enable-configuration*** = <ASCII string>

Enable configuration logs you in to the radio with Supervisor privileges. Supervisor privileges allow you to change parameters.

To view radio parameters:

1. Log in to a unit.
2. At the prompt, enter:  
***change-password enable-monitor*** = <ASCII String>

Enable monitor password logs you in to the radio with User privileges. User privileges do not allow you to change parameters.

### 6.5.3 Challenge Password Procedure

The challenge password procedure enables you to securely retrieve a lost login password.

1. At the login prompt, enter  
***pass-key***  
The pass-key command is case sensitive and has no spaces. The VIP 110-24 will return a 20-character long sequence of numbers and letters.
2. Forward the 20-character sequence to EION Customer Support at:  
[http://www.eionwireless.com/support/tech\\_support.php](http://www.eionwireless.com/support/tech_support.php)  
After receiving and verifying the 20-character sequence, EION Customer Support will send you a Challenge Password License Key.
3. At the login prompt, enter:  
***unlock-key <Challenge Password License Key>***  
When you type characters in the password field, the characters appear as asterisks (\*\*\*\*\*). To prevent typing errors, copy and paste the Challenge Password License Key at the login prompt.  
Once the VIP 110-24 verifies that 24 hours has not passed since the creation of the 20-character sequence, the Challenge Password will log you in to the system.
4. Create a new password. At the prompt, enter  
***change-password=<new password>***
5. Store your new password in a secure location.

The License Key is time sensitive. The VIP 110-24 allows only 24 hours between the creation of the 20-character sequence and when the Challenge Password License Key is entered. If you enter the License Key more than 24 hours after the creation of the 20-character sequence, the License Key is invalid.

## **6.6 Runtime and Uptime Clocks**

The Runtime Clock and Uptime Clocks are timers that enable you to keep track of your VIP performance throughout its operational lifetime.

The Uptime counter keeps track of the operational time of your VIP in days and hours. The Uptime Clock starts from the time you upgrade your firmware to vip02-60-01. The Uptime counter will not work retroactively; it will not record time before the installation of vip02-60-01 firmware.

The Runtime counter is similar in operation to the Uptime Clock except that the Runtime counter restarts with each reboot.

## **6.7 IP Address Propagation**

With IP Address Propagation, you can view the IP address of all radios in the VIP network.

## **7 COMMANDS**

### **7.1 Configuration techniques**

There are three ways to configure the radio. One uses the auxiliary port at the bottom of the unit and consists of an asynchronous RS-232 link used for issuing configuration commands and monitoring the local radio status and performance. This port is always set to operate with the following parameters:

- Baud rate: 9600
- Word length: 8 bits
- Parity: none
- Stop bits: 1

This console port allows configuring and monitoring only the local radio, i.e. you can not monitor and configure any of the remote radios reachable through RF.

A preferred configuration method uses the Ethernet connection to the radio to perform the configuration. This approach has the advantage that any radio reachable across the Ethernet, or the RF link, can be configured from a single PC. Additionally the Ethernet connection is more readily available indoors than the console port.

In order to use the Ethernet connection to configure the radios the “Ethernet Console Program” (Econsole) needs to be installed at a PC. This PC must be connected to the LAN where one or more *VIP 110-24* is connected. From this PC it is then possible to configure not only the radios directly connected to the LAN, but also all other radios reachable through one or more RF hops. Refer to Appendix E for instructions on the installation of Econsole.

The third configuration method is using Telnet from a remote location. Telnet is explained in more detail in section 8.

After power up the radio performs several diagnostic and calibration tests. At the end of these tests it outputs the command prompt. The default prompt is:

```
EION-nnnnn #>
```

where nnnnn are the last five digits of the radio serial number. If a node “name” has been assigned to the node, the prompt will be that name.

The “help” command provides a list of all the commands available. To get more detailed help for a specific command, type “help command-name”. Appendix A lists all the commands available.

The radio keeps a history of several of the previously issued commands. Those commands can be viewed by pressing the up-arrow and down-arrow keys on the keyboard. Any of those previously issued commands can then be edited and reentered by pressing the <Carriage Return> key.

### **7.2 Command syntax**

The command interpreter in the *VIP 110-24* is designed to accommodate both a novice as well as an expert operator. All commands and parameters have descriptive names so that they are easily

remembered and their meaning is clear. In order to be descriptive however, those commands are sometimes long. As the operator becomes familiar with the command language, typing the complete words could become cumbersome. The *VIP 110-24* command interpreter recognizes any abbreviations to commands and parameter names, as long as they are unambiguous. If an ambiguous command is entered, the radio will output all possible choices.

Commands have the following generic form:

*command parameter=value parameter=value*

Following is a brief list of syntax rules:

- Words (for commands, parameters, or values) can be abbreviated to a point where they are unambiguous.
- Some commands or parameters consist of compound words separated by a hyphen. With compound words, the hyphen is optional. Additionally each word in a compound word can be abbreviated separately. For example, the following are all valid abbreviations for the command "save-configuration": "save", "savec" s-c" "sc".
- The parameter and value lists are context sensitive, i.e., in order to solve ambiguities the command interpreter only considers parameters valid for current command, or values valid for the current parameter.
- The arguments "parameter=value" must be entered with no blank spaces on either side of the '=' sign. Those arguments (parameter/value pairs) can be listed in any order.
- Even though parameters can be listed in any order, there is a "natural" order known by the command interpreter. This allows the user to specify parameter values without having to type the parameter names. For example the command **>spectrum-analysis input=a-antenna display=table** can be entered as (using abbreviation rules as well):  
**>spa a t**
- Using the preceding rule, for commands that have a single argument, the "parameter name" part of the argument is always optional, i.e., you can enter:  
*>command value*

For example the command:

**>show-tables table=radio-nodes**

can be shortened to any of the following:

**>show-tables radio-nodes**

**>show radio**

**>show rn**

**>sh**

- Not all parameters associated with a command need to be specified. Depending on the command, when a parameter is omitted it either assumes a default value or keeps the last value assigned to that parameter.

The following sections describe the various commands grouped according to their functionality. A summary list of all commands are contained in Appendices A and B.

### 7.3 License Key Options

The VIP 110-24 has the ability to add features via a “license key” command (see Section 7.13). These license keys offer a variety of additional features and capabilities to the radio. Some of the commands listed below can only be accessed if the appropriate license key has been installed. Please consult your authorized distributor or sales representative for a list of available license key features. Commands noted with an “\*” are only available via a license key upgrade.

### 7.4 Configuration Management Commands

A “radio configuration” consists of a set of programmable parameters that define the radio operation with regard to a variety of operating modes. The radio holds three configurations at all times, identified as “current”, “main”, and “factory”.

The “main” configuration is stored in non-volatile memory. It can be loaded into the “current” configuration with the “load” command. On power up the radio loads the “main” configuration from non-volatile memory into the current configuration.

The “current” configuration is the set of parameters currently being used and can be modified by the operator through several commands. This configuration is volatile. If the current configuration has been modified it should be saved using the “save” command. Otherwise the modifications will be lost if power is removed. The current configuration can be saved to and loaded from a file stored in the flash or tmp directories.

The “factory” configuration cannot be modified by the operator and is used to return the radio to the factory default condition. It is useful as a starting point to create a customized configuration.

The “alternate” configuration is stored in non-volatile memory. It can be loaded into the “current” configuration with the “load” command.

The access to change the radio configuration can be password protected. This password is set by the user with the “change-password” command. Once a password is set, issue the “lock” command to prevent any unauthorized changes to the configuration. Once locked, the configuration can only be modified by issuing the “unlock” command with the correct password.

When the configuration is unlocked, the radio prompt ends with the characters ‘#>’ to remind the user that the configuration is unlocked. In locked mode the prompt does not include the ‘#’ character. Once a password is set, the radio will automatically lock the configuration after 10 minutes without any commands being issued.

The configuration management commands are listed below:

**change-password**

***change-password enable-configuration= “ASCII string”***

This command allows the user to set or change a password used to “lock” and “unlock” access to the commands that change the radio configuration. The *VIP 110-24* is shipped with no password which allows access to all commands. Once a password is set and the configuration is locked, the password is needed to unlock the access to those commands. After changing the password you should also issue the “save-configuration” command to save the new password in non-volatile memory.

Example:

> **change-password enable-configuration=bh7g8**

***change-password enable-monitor= “ASCII string”***

This command allows the user to change the password used for read only access to the VIP.

**WARNING**

The *VIP 110-24* is shipped with no password. If the “change-password” command is issued make sure you do not forget the password. Once locked, to recover a lost password, you must use the Challenge Password Procedure (Section 6.5) to recover your password.

**display-configuration**

***source= current or main or alternate or factory***

Displays all the parameter values for the specified configuration. If the source is not specified it defaults to “current”. A sample output is shown below.

```

-----
NODE Name:      Bank           Network ID:    42
Type:          Leaf           Location:     Wall Street
Anchor:        No             Contact:      Greenspan
-----
IP   Address:    207.154.90.81   SNMP Manager  Community    Access
     Netmask:    255.255.255.0   1 207.154.103.12 public        g
     Gateway:    207.154.90.1   2 207.154.103.18 public        gst
                                     3
                                     4
Time Zone:      PST
-----
FLOW RATES(kbps):  TX   RX   RF-LINKS:      Ch  Spd  Pwr  Ant
Minimum          10   10   * To Parent:   11  23   A
Maximum          10000 10000 * From Parent:  5  11  23   A
                25   B
Max Cycle (ms):   100   NN Poll 1:    5   18   B
Max Bytes/cycle:  76000 NN Poll 2:    35  18   B
-----
ETHERNET
Station t/o (sec): 30   Single Node Reboot Timeout (sec): 900
Multicast t/o (sec): 600 Antenna Alignment Aid: Off
Speed: Auto (10 FD)  EVENT-LOG-LEVELS - Print: 3 Save: 5
-----

```

A few notes about this display:

1. The Network ID field is only displayed if the configuration is unlocked. Otherwise it will be blank.
2. The “asterisks” in the RF-LINKS field indicate which links are active for the current configuration. In the example above, since the radio is configured as a “leaf”, only the links “to” and “from” the parent are relevant.

The following table maps the parameters displayed to the command that is used to change those parameters. Refer to the command for additional information about those parameters.

Examples:

```
> display-configuration source=current
> discon
```

Field / Parameter	Command
Node	node
IP	ip-configuration
SNMP	snmp
Flow rates	max-flow-rate min-flow-rate
RF-Links	rf-from-parent rf-to-parent rf-from-children rf-nnp-1 rf-nnp-2
Ethernet	ethernet
Single Node Reboot Timeout	single-node-reboot-timeout
Antenna Alignment Aid	antenna-alignment-aid
Event Log Levels	max-event

### load-configuration

*source= main or alternate or factory or file*  
*input-file=<string>*

Loads the specified configuration into the current set of parameters controlling the radio operation. If no source is specified it defaults to the “main” configuration.

Examples:

```
> load-configuration source=factory
> load
```

### lock

This command locks the access to all the commands that can alter the radio configuration. Once locked use the “unlock” command to regain access to those commands. Note that a password must be set prior to the “lock” command being issued (the radios are shipped with no password), otherwise the lock command has no effect. If a password is set, the radio automatically “locks” the configuration at the end of 10 minutes with no command activity.

## save-configuration

*destination=main* or *alternate* or *file*  
*output-file=<string>*

Saves the current set of radio operating parameters into one of the two non-volatile configurations. If the destination is not specified it defaults to main.

The save config command will not save the current IP address information if DHCP is enabled.

Examples:

```
> save-configuration destination=main
> save
```

## unlock

*enable-configuration="ASCII string"*

This command, with the correct password, unlocks the access to the commands that allow the radio configuration to be altered.

Examples:

```
> unlock enable-configuration=bh7g8
```

## 7.5 Major Configuration Parameters

These commands change several operating parameters of the radio that are part of the radio "configuration". When entering commands with multiple parameters, if a parameter is not included, that parameter keeps its current value.

### max-flow-rate

*transmit-kbps=1...10000*

Specifies the maximum data rate that the radio will accept from its Ethernet port to be offered into the VINE RF network, even during idle periods.

*receive-kbps=1...10000*

Specifies the maximum data rate that the anchor radio will accept from its Ethernet, addressed to this specific node, even during idle periods.

Examples:

```
> max-flow-rate receive-kbps=1024
> maxfl tr=512 re=256
```

### min-flow-rate

*transmit-kbps=1...8000*

Specifies the minimum data rate that the radio will accept from the Ethernet port to be offered into the VINE network, even during congested periods. This is equivalent to the "Committed Information Rate (CIR)" in a frame relay environment.

***receive-kbps=1...8000***

Specifies the minimum data rate that the anchor radio will accept from its Ethernet, addressed to this specific node, even during congested periods. This is equivalent to the "Committed Information Rate (CIR)" in a frame relay environment.

Examples:

**> min-flow-rate transmit-kbps=500**

**node**

***network-id=0...4,294,967,295***

The network ID is a network wide value that needs to be the same for all the nodes in the network. When a new node attempts to attach to the network, it transmits the network ID. The parent radio checks if this network ID matches its own network ID. If this check fails the new node is not admitted into the network.

**Note:** If a root or repeater is configured with network-id=0, the network-id of the attaching node (leaf or repeater) will be ignored and the unit will be allowed to attach regardless of its network-id. To maintain network security, insure a none 0 network-id is set. This functionality is a change from previous versions of VIP software.

***name="ASCII string"***

Gives the node a meaningful name for further reference. This name will be used as the command prompt. It is also used to identify the node in a variety of commands and displays. The name field can be up to 11 characters with no spaces. If spaces are desired, you may include the whole name in quotation marks.

***type=root or repeater or leaf***

The node type defines the operation of the radio within the VINE network (see section 3). The type can be set to one of three values:

**root:** The root radio is the logical hub of the network and controls the network timing. There must be only one root in a VINE network. The root radio is the only radio in the VINE network that has no "parent". The root radio periodically transmits "new node polls" to acquire new children.

**repeater:** The repeater nodes are subsidiary to the root or other repeaters. A repeater node acts as a slave to its parent and as a master to its children. Repeaters also keep searching for new child nodes by performing "new node polls".

**leaf:** A leaf node is just like a repeater except that it does not perform new node polls. This results in a slight optimization of network timing.

***anchor=yes or no***

Some network applications have the characteristic that the traffic to all radios is originated at a single node in the network. That same node is also the destination of all traffic transmitted by all other radios. This is the case for an Internet Access application for example. For these applications this special node should be designated as the “anchor” (only one node in the network should be the anchor). The anchor node enforces the receive flow rates that are specified with the “min-flow-rate” and “max-flow-rate” commands for each radio.

It is generally more efficient to make the anchor node the same as the root node although it is not necessary to do so.

***location="ASCII string"***

Optional parameter to define the location of the node. This field is displayed in the “Display-configuration” output and also reported through SNMP. This field is used for information only. The location string can be up to 25 characters with no spaces. If spaces are desired, you may include the whole string in quotation marks.

***contact="ASCII string"***

Optional parameter to define the contact for maintenance purposes. This field is displayed in the “Display-configuration” output and also reported through SNMP. This field is used for information only. The contact string can be up to 25 characters with no spaces. If spaces are desired, you may include the whole string in quotation marks.

Examples:

```
>node net-id=2754 name=bank type=leaf location="wall street" contact=964-5848
```

**single-node-reboot-timeout**

***timeout-sec=30..3600***

After power up, a non-root radio attempts to get attached to a parent radio by responding to a “new node poll” transmitted periodically by the root and repeater radios. If a radio fails to get attached (or drops an existing attachment), it will perform a complete reset after the timeout specified in this command.

Similarly, if a root radio has no children for the timeout specified by this command, it will perform a reset.

This feature is useful if a command is issued to a remote radio changing its parameters in such a way that breaks the link to its parent. In that case the remote radio will drop its attachment to the network, wait for the “single-node-reboot-timeout” and then perform a reset. As a result, the radio reverts to the saved configuration, allowing it to get reattached to the network.

Examples:

```
> snrt 60
```

**rf-from-children**

***ch-on-b=5..35***

***ch-on-a=5..35***

This command is sent from a parent radio and configures the channel to be received by this radio's children. The parent radio can be set to receive the children transmissions on either the A or B port or both. The selected channel number is passed to the children in the "new-node-poll" packets.

During installation, use the spectrum analysis command to determine the local interference seen by antenna B. Then select a channel based on the noise/interference levels reported.

Examples:

```
> rf-from-children ch-on-a=15
> rffc chob=25 choa=15
```

### rf-from-parent

```
ch1=5..35
ch1-ant=a-antenna or b-antenna or none
debug=0 or 1
speed-mbps= 1, 2, 5.5, 11
power-dbm=0..23
```

This command configures the channel, speed, and transmit power used in the RF transmissions from the parent to this node. When the radio gets attached to the network, it passes these values to the parent, which will use them in all future RF transmissions to this radio.

When the debug command is set to "1", (or enabled), debugging of the parent acquisition is enabled. If the serial console is connected, the result of the parent search is automatically sent to the serial port every 15 seconds until a parent is found. The search result shows the candidate parent and the associated NNP RSS strength. If Telnet or ECON issued, the command "display-scout" command must be issued. The debugging capability allows the adjustment of the parent acquisition process to suit the existing field environment.

Note that in the normal mode, for the radio to get attached the channel selected by this command must match one of the two "new node poll" channels of the parent. See commands rf-ntp-1 and rf-ntp-2.

Example:

```
>rffp ch=15 sp=2 po=10
```

### Dynamic Power Control

To enable Dynamic power control, use the command:

```
rffp dcp=enable
```

To change the link margin, issue the command:

```
rffp lm=<new link margin>
```

### rf-ntp-1

```
channel=5..35
power-dbm=0..23
```

A node configured as a root or repeater periodically transmits “new node poll” (NNP) packets in one, or optionally two, channels. Nodes that are not yet in the network respond to these poll packets in order to get attached.

This command configures the channel and power used for transmissions of NNP packets (the speed is always 2 Mbps). NNP transmissions in a second channel can be turned on using the “rf-*nnp-2*” command. Note that the children of this radio must have the “rf-from-parent” channel match one of the two NNP channels.

Once a node is attached to the network, the speed and transmit power for the RF links between this node to the child are configured, at the child radio, with the “rf-from-parent” and “rf-to-parent” commands.

Examples:

```
> rfnp1 ch=15 po=18
```

*rf-*nnp-2**

*channel=5..35*

*power-dbm=0..23*

*enabled=0 or 1*

*antenna=a-antenna or b-antenna or none*

A node configured as a root or repeater periodically transmits “new node poll” (NNP) packets in one, or optionally two, channels. Nodes that are not yet in the network respond to these poll packets in order to get attached.

This command configures the optional second New Node Poll channel and power used for transmissions of NNP packets (the speed is always 2 Mbps). The “enable=0 or 1” parameter allows the transmissions in this second channel to be turned off or on. Because the parent radio can transmit two NNPs, any children radios can have a choice of two receive channels. Note that the children of this radio must have the “rf-from-parent” channel match one of the two NNP channels.

Once a node is attached to the network, the speed and transmit power for the RF links between this node to the child are configured at the child radio with the “rf-from-parent” and “rf-to-parent” commands.

The root can use both the A and B antenna for communications with its children. This allows the root to be deployed with two antennas covering different sectors, but still using a single node. Communications for the two antennas are separated in time so there is not inter-antenna interference. To use the dual port mode, new node poll 2 must be enabled and antenna “a” is selected. To insure that the child radios attach to the correct antenna, the transmit channel of new node poll 2 should be offset from the channel at new node poll 1. A channel separation of 1 should be sufficient to prevent cross attachment.

Examples:

```
> rfnp2 ch=35 po=18 en=1
```

*rf-to-parent*

*speed-mbps= 1, 2, 5.5, 11*

*power-dbm=0..23*

The RF speed and transmit power settings for each link are always stored in the child radio. This command configures the speed and transmit power used in the RF transmissions from this radio to its parent.

Example:

```
> rftp sp=2 p=16
```

## rf-plug-n-play

*status= enable, diable*

RF Plug and Play allows a leaf to attach to a parent with little or no prior configuration. The root or repeater must have rf-plug-n-play enabled before a leaf can be installed using the feature. The leaf must be configured with an IP address or DHCP, and have rf-plug-n-play enabled.

After the leaf has attached to a parent and has successfully download a configuration file from the parent, it will be configured will parameters based on the parent's configuration.

## 7.6 Bridge Management Commands

Bridge management commands set and display the specific operating characteristics relating to the operation of the radios as a network.

### ethernet

*speed=auto or 10hdx or 10fdx or 100hdx or off*

Sets the ethernet port speed to auto-negotiate, 10Mbps half-duplex (10hdx), 10 Mbps full-duplex (10fdx), 100 Mbps half-duplex (100hdx) or turns the ethernet port off.

In installations requiring very long outdoors CAT5 cable, operation at 100 Mbps may become unreliable. For this reason the auto-negotiate setting allows only 10 Mbps half or full-duplex. For operation at 100 Mbps you need to specify that speed explicitly.

When the ethernet port is turned "off" no traffic is accepted from the ethernet port, but the radio continues to operate over RF normally. This is useful for a radio configured as a repeater, if the operator wants to turn off the user but needs to keep the service for radios downstream. Note that once the ethernet port is turned off, it can only be turned back on through an RF connection or the RS-232 console port.

*timeout-sec=5..1800*

Sets the time the radio will retain, in its internal table, Ethernet addresses obtained from the network.

*multi-cast-timeout-sec=5..3600*

Sets the time the radio will retain, in its internal table, Ethernet multi-cast addresses obtained from the network.

Examples:

```
> ethernet speed=10fdx timeout=100
```

## packet-switch

The VIP can selectively control the blocking of multicast traffic.

### *multicast-wire=0 or 1*

This command is used to enable or disable blocking of multicast traffic from the LAN (Ethernet) port of the radio. A value of "0" will allow multicast to pass while a value of "1" will block multicast from entering the Ethernet port.

### *multicast-rf=0 or 1*

This command is used to enable or disable blocking of multicast traffic received from the RF side of the radio. A value of "0" will allow multicast to be received by the RF port while a value of "1" will block multicast from entering the RF port. This command is valid only at root and repeater nodes. When enabled, if a root receives any multicast traffic from a child radio, it will not forward the multicast over the radio's RF port, but will send it out the radio's Ethernet port. In other words, if a root receives multicast traffic from a child, it will not re-broadcast that multicast traffic to the other children in the network through RF. If a repeater receives any multicast from a child radio, it will behave in a slightly different fashion. Just like a root, it will send multicast out the LAN but block it from being sent out via RF to the other children attached to the B port, but unlike a root, a repeater will forward the multicast traffic via RF to its parent over the A port.

Examples:

```
> packet-switch multicast-wire=1
```

## polling-list

### *level=1..7*

The VIP has an option that offers dynamic polling. When dynamic polling is activated, active child radios in a multi-point network are polled more frequently than less active or inactive child radios. The activity of a child radio is determined by the availability of inbound and outbound data when the parent polls that radio.

The parent maintains a list of child radios to be polled. Each child radio on the list is slotted to a level according to the activity of the radio. A child radio slotted to a higher level is polled more frequently. The default polling level is 1 that means dynamic polling is disabled. The polling level command is only valid on a parent radio such as a root or repeater.

If a child is a repeater, the repeater is always slotted to the top polling level of its parent and does not move dynamically. The number of polling levels on a repeater must be less than or equal that of its parent. For example, if a root has 3 levels, the repeater can have 3, 2 or 1 levels. If dynamic polling is disabled at the root, the repeater should not have dynamic polling enabled.

With the introduction of dynamic polling, radios on the lower polling levels are polled less frequently. Subsequently, the IP stack response, e.g. ping and SNMP queries, from less active or inactive radios may be slower than an active radio.

A general guide for selecting the appropriate dynamic polling level is that the more child radios a parent has, the lower the polling level. For example, in a network with 25 child radios, it would not be a good idea to set the polling level to 7. In a typical multipoint network, a level of 2 – 4 is recommended.

Examples:

> **polling-list level=3**

## polling-show

*source=current or main or factory or develop*

The polling-show command provides a snapshot of the current polling list and the level at which each child-radio is slotted.

Examples:

> **polling-show source=current**

## show-tables

*table=radio-nodes or ethernet-stations or flow-control or direct-links or default  
format=counts or times*

This command displays a variety of information about the overall VINE network. The contents of the different tables are described below.

### default

If the value “default” is selected or the command “show” is typed without an argument, the following is displayed. This display has three sections, listing first the current time, start time and temperature, then the radio table itself and finally statistics about the links to its direct neighbors.

### >show

```
Current Time: 16:49:26.130 29-Nov-2001 PST
Start Time: 16:17:08.000 29-Nov-2001 PST
Temperature: 36C 96F
```

	Radio	Name	Address	Type	Route	Known since
self	2	towerA	00-00-2d-cb	Repeater		
parent	3	main-office	00-00-2d-b7	ROOT	3	29-Nov 16:23:40
	4	bank	00-00-2d-c3	Leaf	3	29-Nov 16:23:41

### DIRECT LINKS:

	Node #	Name	Ch	Speed Mbps	Pwr dBm	RSSI dBm	Km Miles	Data Pkts	Dropped Pkts	%
to child		broadcast	25	11	18			784		
to	3	office	25	11	18	-62	8.0	211274	0	0
from	3	office	5	11	18	-60	5.0	244245	88458	1271

The “Current Time” and “Start Time” are shown in the format above if the “date” and/or “time” commands have been issued, or the unit has been able to catch a Network Time Protocol packet (NTP) since it was powered up. Otherwise the Start Time shows as 00:00:00 and the Current Time displays the number of hours since the unit was powered up.

In the “radio table” there is one entry per radio in the whole VINE network. The first entry is always the radio itself and has an index of 2 (index 1 reserved for broadcast traffic). If the radio is not the root node the second entry (index 3) is always this node's parent. The remaining entries are for all other radios in the network. The “Route” column shows the direct neighbor that packets are routed to when the packet final destination is the radio entry.

The subsequent table shows statistics for the links to each of the direct radio neighbors. The data packets and dropped data packets field show the total number RF packets with the number and percentage lost. The data and dropped packets fields can be cleared with the use of the monitor-link node-clear=1 command (ref. monitor link command in section 6.7).

### **radio-node**

When this argument is used, only the first part of the “show” command is displayed, i.e., the list of all radios in the network. The table showing the directly connected radios is not displayed.

### **ethernet-stations table**

This table can be displayed in two formats, “counts” (default) and “times”.

#### **>show ethernet**

Ethernet Stations:

#	MAC address	IP address	Radio	--Discard--		--Forward--	
				from	to	from	to
0	ff-ff-ff-ff-ff-ff		0	0	0	0	183
1	00-d0-39-00-2d-cb		-2	0	0	209	165
2	00-a0-cc-66-8e-a6	207.154.90.171	2	136	54	139575	172
3	00-d0-39-00-2d-c3		4	0	0	0	0

#### **>show ethernet times**

Ethernet Stations:

#	MAC address	IP address	Radio	MC	Time added	Idle	VLAN	L
0	ff-ff-ff-ff-ff-ff		0		00:00:00		N/A	N
1	00-d0-39-00-c3-5e	10.2.0.208	-2		00:00:00	0.00		4 N
2	00-0f-ea-50-5a-5b	10.2.0.221	2		01:31:00	0.63	N/A	Y
3	00-d0-39-00-c3-73		2		01:31:06	9.46	N/A	N
4	00-0f-ea-4f-bc-bd	10.2.0.218	4		00:00:05	9.46		4 N

Both formats lists all the ethernet stations attached to any of the radios in the whole VINE network. The tables lists the MAC (Ethernet) address of the station, and, if known, the IP address. The “Radio” column the radio (as an index into the radio-nodes table) where that station is physically attached.

The first entry in the table tracks broadcast traffic while the second entry is always the address of the radio itself.

The “counts” format shows the cumulative number of ethernet packets that have been seen with that MAC addresses in the “source” (from) or the “destination” (to) fields. In bridge mode the radios are in “promiscuous” mode and look at all the ethernet packets in the Local Area Network. The radios “discard” the packets that are known to be local, but “forward” all other packets into the VINE RF network. These are accounted separately in the report.

The “times” format indicates whether that entry is for a “multicast” (MC) address, shows the time when the station was added to the table, and how long since that address has been seen.

When the “idle” time exceeds the time specified by the “ethernet” command, that entry is deleted from the table.

**flow-control**

The “flow-control” argument displays a table with the time the reading was taken as well as the minimum, current, and maximum Tx and Rx values.

**> show flow-control**

```
FLOW RATES (kbps) at 00:10:38.190
  Radio   Min Tx Min Rx   Cur Tx Cur Rx   Max Tx Max Rx
  -----
  totals         0     0         0     0         0     0
```

**direct-links**

The “direct-links” argument displays only the second part of the “show default” command with the radios that are directly connected via RF.

**monitor-cycle**

Monitor Cycle reports the polling cycle of all a radios direct links. Every direct connection that a radio has in a network—for instance, a parent to a child, a child to a repeater, or a child to parent—is displayed in the Monitor Cycle Table.

The table lets you see what is happening with a particular radio, and all its connections, in your network. You can not affect or change any of the parameters in the Monitor Cycle Table. The table has a row for each radio directly connected to the current radio. Table updates occur nearly every second.

**Max bytes:** 76000: the **flow-control** commands parameter and its current values.

**Max cycle:** 100 ms: the **flow-control** commands parameter and its current values.

Max bytes: 76000  
Max cycle: 100 ms

#	Name	Min	Max	t1	t2	avg	last	Quota	Balnc	Age	Shed
0	broadcast	10	5500	52	99	6.23		4125	6874	0	27809
1	broadcast	10	5500	52	99	0.00		0	0	0	0
2	EION-45285	10	10000	37	99	5.71	5.73	6250	12500	0	0
3	EION-15882	10	10000	37	99	6.23	11.41	7500	12500	0	0

**#:** the index of the link. These parameters will match up with the index numbers that the show command displays.

**name:** name of the radio.

**Min:** configured transmit min-flow-rate for this radio.

**Max:** configured transmit max-flow-rate for this radio.

**t1:** the time in milliseconds that corresponds to the first intersection point in the graph. See VINE Network documentation on page 21.

**t2:** the time in milliseconds that corresponds to the second intersection point in the graph. See VINE Network documentation on page 21. (The t1 and t2 columns are calculated using the Max cycle and Max bytes parameters, along with the average cycle time of the node in question.)

**avg:** the average amount time, in milliseconds, between cycles when talking to this radio.

**last:** the last amount of time in milliseconds between cycles when talking to this radio.

**quota:** the number of bytes that can be transmitted to this radio in the next cycle.

**balance:** the number of left-over bytes from previous cycle. The balance is added to the quota, and can be negative if the quota is exceeded.

**Age:** the number of packets destined for this radio that have been discarded because they were not sent to the radio in a timely fashion.

**Shed:** the number of packets destined for this radio that have been discarded because they would have exceeded the quota. (The Shed and Age columns should not have too many packets listed. If they do, it means data isn't getting to your radios because the network is too busy. If your network is too busy to effectively handle all traffic, contact EION or your distributor to discuss upgrading your radios or adding additional radios to your network.)

## 7.7 Internet Protocol (IP) Management Commands

The IP Management commands configure the radio IP protocol parameters which allow the radio to be monitored and configured through Telnet and SNMP. Refer to section 8 for a more detailed explanation on those two applications.

### ip-configuration

```
address=<ip address>
netmask=<string>
gateway=<ip address>
```

This command configures the radio IP address, netmask and gateway. The radios are shipped with a default IP address of 192.168.1.100 and mask of 255.255.255.0. Since all nodes in a VINE network are bridged together they all belong to the same "internet network". Because of this, a VINE network WILL work with all of the radios having the same IP address. However, EION Wireless strongly recommends that the IP address of each radio be set to a unique value to prevent unpredictable behavior in any of the attached LAN's.

Example:

```
> ipconfig add=207.154.90.81 netmask=255.255.255.0 gateway=207.154.90.2
```

**Note:** The ip-configuration command will not allow changes to the IP address settings, and will display the DHCP acquired IP address settings while DHCP is enabled. Before enabling DHCP, a default IP address should be configured for use by the VIP if an address is not acquired or if DHCP is disabled. The static IP address you assign can be viewed using the command 'display-config main' while DHCP is enabled.

### ping

```
destination=<string>
```

***count=0..500***  
***size-bytes=32..1400***

This command causes the radio to “ping” the destination address and display the results. The “ping” packet consists of an ICMP packet with a length specified by the “size-bytes” parameter. The destination is any valid IP address. When the destination host receives the packet it generates a reply of the same size. Upon receiving the reply the radio displays the round trip delay. This process is repeated the number of times specified by the “count” parameter (default to 4).

Example:

```
> ping 207.154.90.81 count=10 size=100
```

## snmp

The radio runs an SNMP agent which allows up to four IP addresses to be specified as valid SNMP managers. This command configures those IP addresses and the type of access allowed. You can issue the command up to four times to specify each separate IP address manager. The radios are shipped with all entries blank. While no entries are specified, the unit accepts SNMP “get” requests from any IP address with the “public” community. Once one or more entries are specified, the radio only responds to requests from the specific IP addresses listed. This list of authorized managers is also used for validating Telnet requests.

Refer to section 8 for an overview of Network Management using SNMP and Telnet.

***manager=<ip address>***

Specifies one valid IP address where the SNMP manager or Telnet session will run.

***community=<string>***

Any string of up to 9 characters. For SNMP requests the “community” field in the request packet from this IP address must match this parameter. For a Telnet session the username entered when initiating the session from this IP address must match this string. If this parameter is not specified it defaults to “public”. Note that you must always enter the “manager” IP address in the same command line that sets the “community” value.

***access=g or gs or gst or gt***

SNMP access type authorized for this IP manager. Specify as any combination of three letters: g (get), s (set) and t(trap). If this parameter is not specified it defaults to “get”. Note that you must always enter the “manager” IP address in the same command line that sets the “access” value.

***authentication-traps=0 or 1***

Specifies whether an “authentication trap” should be generated if a SNMP request is received that can not be honored (due to invalid IP address, community or access fields). When enabled, all IP managers that have “trap” access will receive this trap.

***delete=1..4***

Allows deleting one entry in the SNMP table. The number 1..4 refer to the entry number as listed in the “display configuration” report.

Example:

```
> snmp manager=207.154.90.81 com=support access=gst
```

## dhcp

*action=rfwire/disable/release or renew*

*rf*—attempts to obtain an IP address using the RF connection only.

*wire*—attempts to obtain an IP address using the Ethernet connection only.

*auto*—uses the wired or wireless connection depending on the VIP 110-24 configuration. Leaves and Repeaters use a wireless connection, while Roots use wired connection.

*disable*—suspends DHCP. After disabling DHCP, the VIP to restore the IP address stored in the main configuration (set using the ‘ip-configuration’ command).

*release*—frees the IP lease, but leaves DHCP enabled so the radio will acquire a new lease.

*renew*—forces the DHCP Client to attempt an immediate lease renewal of the current IP address.

**Note:** Before enabling DHCP, use the ip-configuration command to setup a default IP address for the unit. This address will be restored if DHCP is unable to acquire an address within approximately 5 minutes, or if DHCP is disabled. If you are changing DHCP settings via telnet, use the command ‘display-config main’ and note the default IP address settings.

## web-download

The web-download command allows the user to transfer a file from a website and the VIP 110-24 will save the file to the specified folder in *flash/* or *tmp/* storage.

*web-download<source>[destination]*

*<source>* is the current IP address of the file, a port may be specified in the IP address. If a port is not specified port 80 is used by default.

*[destination]* is an optional field that specifies where the where the downloaded file is stored on the VIP.

## 7.8 VLAN Commands

### vlan-config

VLAN Configuration commands are concerned with configuring a radio to add VLAN tags to outgoing Ethernet packets.

*switch=enable or disable*

The **switch** parameter defines how the radio sends Ethernet packets, either by adding a VLAN tag to every basic Ethernet packet that arrives at the radio, or by not tagging basic Ethernet packets.

You can **enable** or **disable** the VLAN switch mode. When **enabled**, VLAN switch mode adds a VLAN tag to a basic Ethernet packet arriving over a wired Ethernet port as it is sent. When **disabled**, the radio sends all basic Ethernet packets whether they are tagged or untagged.

**id=1..4094**

The **id** parameter defines the ID number that is used when adding VLAN tags. The ID range is from 1 to 4094.

**priority=0..7**

The **priority** parameter enables you to set the priority when adding VLAN tags. The priority range is from 0 to 7; with 0 being the traffic that receives the lowest priority on the network, and 7 being the traffic that receives the highest priority on the network.

## vlan-registration-table

VLAN Registration Table commands are mainly concerned with defining how incoming VLAN tagged Ethernet packets are handled: filtered, tagged, untagged, dropped or forwarded. There are a maximum of 16 entries in a Registration Table. The first entry of a Registration Table is the default VLAN ID. The default VLAN ID is always the host radio's VLAN ID

**look-up=enable or disable**

The **look-up** parameter defines radio access to the Registration Table for directions on how to handle incoming Ethernet packets. You can **enable** or **disable** the VLAN Registration Table lookup. When enabled, packets are processed based on information in the Registration Table. When disabled, the radio will disregard the Registration Table settings and allow basic Ethernet packets and VLAN tagged Ethernet packets to pass transparently.

**action=view/add/modify/delete or clear**

The VLAN **action** parameter allows you to view and make changes to the Registration Table. You can **view**, **add**, **modify**, **delete**, or **clear** the Registration Table. The default parameter is view.

**id=1...4094**

The **id** parameter allows you to create and updates VLAN IDs in the Registration Table. The ID range is from **1** to **4094**. You must specify a VLAN ID with the Registration Table **action** command to use add, modify, or delete actions.

**ethernet-registration=fixed or forbidden**

The **ethernet-registration** parameter enables you to determine how incoming Ethernet packets with a particular VLAN ID, destined for a wired Ethernet port, are handled. You can set the Ethernet Registration to **fixed** or **forbidden**. When set to **fixed**, all Ethernet packets with this VLAN ID will pass. When set to **forbidden**, all Ethernet packets with this VLAN ID are dropped.

***ethernet-tagging=tagged or untagged***

The ***ethernet-tagging*** parameter enables you to determine how incoming Ethernet packets with this VLAN ID, destined for a wired Ethernet port, will pass through the network. You can set VLAN Ethernet Tagging to ***tag*** or ***untag***. When set to ***tag***, all Ethernet packets with this VLAN ID pass with a VLAN tag attached. When set to ***untag***, all Ethernet packets with this VLAN ID have the VLAN tag removed before passing.

***rf-registration=fixed or forbidden***

The ***rf-registration*** parameter enables you to determine how incoming Ethernet packets with this VLAN ID, destined for an RF port, are handled. You can set the RF Registration to ***fixed*** or ***forbidden***. When set to ***fixed***, all Ethernet packets with this VLAN ID will pass. When set to ***forbidden***, all Ethernet packets with this VLAN ID are dropped.

***rf-tagging=tag or untag***

The ***rf-tagging*** parameter enables you to determine how incoming Ethernet packets with this VLAN ID, destined for a wired Ethernet port, will pass through the network. You can set VLAN RF Tagging to ***tag*** or ***untag***. When set to ***tag***, all Ethernet packets with this VLAN ID pass with a VLAN tag. When set to ***untag***, all Ethernet packets with this VLAN ID have the VLAN tag removed before passing.

**vlan-management**

The VLAN Management command and parameters are independent of either Configuration commands or Registration Table commands. The VLAN Management command and parameters are for network management and administration. When enabled, you can only access a radio through the configured VLAN.

vlan-id 1 provides a special exception for management access to the radio. If vlan-management id=1, untagged access will be granted, but tagged access must be done using vlan 1.

***management-switch=enable or disable***

The ***management-switch*** parameter defines whether or not to restrict access to a specific VLAN. You can set VLAN Management Switch to ***enable*** or ***disable***. When ***enabled***, only packets with a VLAN ID specified by the management-id command will pass to the VIPs local stack. You cannot ping, telnet, or ftp the VIP unless the packets have the proper VLAN ID. When ***disabled***, you can ping or access a radio by ftp or telnet from any VLAN or non-VLAN client.

***management-id=1...4094***

The ***management-id*** parameter defines which Ethernet packets will pass to the VIPs local stack. The ID range is from ***1*** to ***4094***.

## 7.9 Installation and Link Monitoring Commands

These commands are useful as installation aids and also for monitoring link statistics after the link is established.

## antenna-alignment-aid

***output=audio*** or ***off***

***node= node-name or #node-number***

With the antenna alignment aid set to “audio” the radio outputs, through the auxiliary port, an audio signal with a pitch proportional to the Receive Signal Strength (RSS) level of packets received from the specified node. EION provides a special cable adapter that converts the three-pin auxiliary port connector into a standard female audio jack. Use this cable to connect the auxiliary port to a pair of standard headphones while aligning the antenna.

The node parameter selects the remote radio that the antenna needs to be pointing to. You can specify either the node name or the node number (preceded by the # character), as listed by the “show” command. In order to align antenna A (at a leaf or repeater node), set the node parameter to #3, which is always the parent radio.

In a typical VINE application antenna B is a widebeam antenna that may not require careful alignment. However, in some situations antenna B can be a directional antenna and it may be desirable to point it precisely to one of the node's children (point to point application for example). In that case set the “node” parameter to the child radio that you desire pointing the antenna B to. In this case the RF link to the child needs to be up before the alignment aid can be turned ON.

When the command to turn the audio output ON is issued, the radio displays a line indicating which antenna is being aligned. Additionally the radio plays one of two short tunes identifying antenna A or B.

While the antenna alignment is set to “audio” the RS-232 console output is not available. When the antenna alignment output is set to “off” the auxiliary port output reverts to RS-232 console.

The antenna alignment output setting (“audio” or “off”) can also be saved as part of the radio configuration. When the radio powers up with the alignment set to audio, the node number defaults to #3 (parent node). This is useful to take a pre-configured radio to an installation site with no need to turn the antenna alignment ON (through a terminal) after power up.

Example:

```
>aaa audio #4
>aaa off
```

## display-environment

When a non-root radio is powered up it automatically performs a “monitor-environment” procedure (through antenna A and on the selected outbound channel), to identify the best parent candidate. The “display-environment” command displays a report of the environment as seen by the radio at the time it got attached to the network. Refer to the “monitor-environment” command for details about this report.

## display-scout

See “rf-from-parent” for details about this command.

## monitor-environment

*channel=0..50*

*input=a-antenna or b-antenna*

The “monitor-environment” command sets the radio in receive only mode and collects packets through the specified antenna. If the channel number is not specified, the radio dwells consecutively in each of the channels that are currently specified (shown in the “display configuration” report). Otherwise it will set the receiver continuously to the specified channel.

For each packet received the radio identifies its source and whether the packet is a “new node poll” (NNP) or otherwise. While in this mode the radio refreshes a report periodically that includes, for each source, a separate line with the statistics of the NNP packets and other packets. These statistics include a cumulative count of packets received and the Received Signal Strength (RSS) of those packets.

Among all the sources that broadcast new node polls in the “rf-from-parent” channel, the radio identifies the one with the strongest signal. This is indicated with the “>>” characters in the left column of the report. When the monitor environment mode is exited (by depressing any key), the radio will first attempt to attach to that potential parent.

While the radio is in the monitor environment mode, it is detached from the network. For this reason this mode cannot be invoked from a remote radio. Additionally, a radio configured as the root is not allowed to go into monitor environment mode since this would bring down the whole network.

Example:

```
>monitor-environment ch=25 in=b
>monenv
```

## monitor-flow

This command continuously displays the ethernet data rates between this radio and all the other radios in the VINE network. It is particularly useful in applications with an “anchor” mode. In that case, performing a “monitor-flow” at the anchor, allows tracking the current data rates in the whole network. At the anchor the output also includes the information on the max and min flow rates of each node.

## monitor-link

*node= node-name or #node-number*

*clear=0 or 1*

This command continuously displays RF link statistics with any of this radio’s direct neighbors. The neighbor node is identified either by the node name or by the node number (as displayed with the “show” command) preceded by the # character. The statistics include, for each direction of the link, the channel, speed, transmit power, RSSI, link distance and cumulative number of packets sent and lost.

The “clear=1” parameter clears the cumulative counts in the report.

Examples:

```
>monitor-link node=main_bank02
>monitor-link clear=1
```

## spectrum-analysis

*input=a-antenna or b-antenna*  
*display=graph or table*  
*dwell-time-ms=0..1000*

This command performs a scan of all the channels in the band, dwelling on each channel for the specified amount of time (defaults to 20 milliseconds). While on each channel it measures the RSSI for that channel and stores its peak value. It then displays the data collected in a graphical or table formats (defaults to "graph").

During the test the RF input into the radio can be selected between one of the two antennas.

Note that even though the VIP 110-24 channels are spaced 2 MHz apart, the receiver RF bandwidth is approximately 18 MHz. Therefore the RSSI value reported for each channel represents the total energy in an 18 MHz band centered around that channel. For this reason, a narrow band transmitter will show up in the spectrum analysis report as a lobe with 18 MHz bandwidth. Conversely, you do not need to find a quiet 18 MHz wide region in the spectrum analysis report to select a quiet channel, i.e., any single channel sample that shows a low "noise" level, is a good candidate to select as a receive channel.

If this command is issued remotely, the dwell time should be kept below 80 ms. This is because while a spectrum analysis is being performed, the radio does not respond to polls from the parent, or poll its children. If the command takes too long to execute, the node will be dropped from the VINE network and the report will not be received by the remote station.

Examples:

```
>spectrum-analysis input=b-antenna
>spa dwell=500
```

## test-rf-link

*node=node-name or #node-number*  
*packet-length-bytes=1...1500*  
*repeat-delay-ms=0...3000*

This command tests the quality of the Ethernet data transfer over the RF link(s) between any two radios in the VINE network. The radio where the command is issued initiates the test by transmitting test packets to the radio identified by the "node" parameter, which may be several hops away. The destination "node" is identified either by the node name or by the node number (as displayed with the "show" command) preceded by the # character. When the destination node receives a test packet, it checks if any packets are missing and sends a reply packet back to the originating radio.

The test packets can be of any length specified by the user (defaults to the maximum length). The "repeat-delay-ms" parameter specifies the time between packets. It defaults to zero, which result in transmitting a new packet immediately after the reply to the previous packet is received. The radio waits up to two seconds for the reply, then declares the packet missed and restarts transmissions.

The originating radio continuously reports the cumulative count of packets transmitted, missed packets at the remote radio and missed packets on the reply link (cumulative count as well as a percentage of the total), and turn around time statistics (minimum, maximum and recent average).

To stop the test, press any key.

Examples:

```
>test-rf-link node=#4 packet-len=100 repeat=2000
>test-rf #3
```

time-analysis

```
channel=0..50
input=a-antenna or b-antenna
display=graph or table
dwell-time-ms=1, 2, 5, 10, 20, 50, 100, 200, 500
```

This command measures the RSSI for a single channel over a period of time. Each “sample” consists of the maximum RSSI measured during the dwell time specified (defaults to 20 milliseconds). After collecting 60 samples the RSSI values are displayed graphically or numerically (defaults to “graph”).

In this test the RF input into the radio can be selected between one of the two antennas.

Example:

```
>time-analysis input=b-antenna
>tia in=a dis=t dwell=500
```

## 7.10 Event Logging Commands

The VIP 110-24 keeps track of various significant events in an “event log”. This event log holds up to 500 events. The first 100 entries in the log are filled sequentially after power up and are not overwritten. The remaining 400 entries consist of the last 400 events recorded. All events are time-tagged with system time.

Events are classified in different categories from level 0 (catastrophic error) to 7 (information).

clear-log

```
region= all-events or reboot-reasons
```

This command clears the contents of the system event log from the specified “region”. After a code upgrade it is recommended to clear the reboot reasons since the pointer in non-volatile memory pointing to the reason message may no longer be valid.

display-log

```
region=end or beginning or all-events or reboot-reasons
length=1..500
id=0..200
min-level=0..7
```

### ***max-level=0..7***

This command outputs to the terminal the specified “region” of the event log. The “length” parameter specifies the number of events to output (defaults to 10). The remaining parameters provide filters to leave out specific events. If the “id” parameter is specified, only the event identified by that id will be displayed. The “min-level” and “max-level” settings allow the user to display only the events with the specified category range.

The “reboot-reasons” region of the event log consist of the last four events that that caused the radio to reboot. These events are stored in non-volatile memory. The time tag in these events is the time the radio was up since it was rebooted, not the time of day.

Examples:

```
>display-log region=all  
>display-log region=all length=300 min-level=2 max-level=6
```

### **max-event**

Sets the event severity level that should be saved or displayed. These two parameters are saved as part of the configuration

### ***save=0..7***

Only events of the specified level or below will be saved in the event log.

### ***print=0..7***

Events of the specified level or below will be output to the terminal as they occur.

Examples:

```
>max-event print=6
```

### **email**

#### ***alerts=enable*** or ***disable***

The *alerts* parameter allows you to ***enable*** or ***disable*** Email Alarm Client.

#### ***e-mail-address=<email@somewhere.com>***

The *e-mail-address* parameter enables you to determine to which email address the alarms will be sent.

#### ***smtp-ip-address=<w.x.y.z>***

The *smtp-ip-address* parameter defines the IP address of the SMTP server that sends the email alarms. This feature does not support SMTP servers that require authentication.

#### ***interval=<x>***

The *interval* parameter enables you to set the length of time in minutes a node will wait between sending alarms. If a specific node encounters and records multiple alarms, the Email Alert Schedule prevents a flood of emails occurring in a short period of time.

The e-mails will be sent using the node name as the source (from) e-mail address.

## 7.11 Scripts

The VIP has the ability to create and run configuration scripts. These are text files containing command line instructions to configure the unit. When modifying a script file manually, insure the proper syntax and command sequence is used.

### create-script

*filename=<string>*  
*leaf-script=enable* or *disable*

The leaf script parameter is only valid on roots and repeaters. The script file created by create script is command line text that can be used to reconfigure the unit. The file can saved on a pc using ftp and edited using a text editor.

Examples:

**run-script**  
**script-file=<string>**  
**results-file=<string>**

The specified file is run.

If the script file does not include a save configuration line at the end, it must be manually entered at the command line after the script is finished or changes may be lost after a reboot.

The autorun directory is used to automatically run a script file. Once the file has been copied to the directory, it will be run allowing for configuration scripts to be copied to a unit by ftp and run without having to telnet into the unit.

## 7.12 File Utilities

The VIP 110-24 maintains a file system that allows multiple programs to be stored in either non-volatile flash PROM or volatile RAM. New programs can be downloaded into the VIP110-24 memory through the auxiliary port, through the Ethernet port, or to remote radios across RF links in a VINE network.

One of the programs in flash PROM is designated as the default program to run after reboot. On power up that program is copied from PROM into RAM and the code runs out of RAM.

Both sections of memory (non-volatile flash PROM and volatile RAM) are segregated into two "directories". The non-volatile flash PROM is called "flash" signifying the flash PROM and the volatile RAM is called "tmp" signifying the temporary status of the program. Use the "directory" command to view the programs loaded and whether they are in non-volatile or volatile memory.

Any program can be invoked with the command "run" without making it the default file. This is useful when upgrading the software over an RF link as a way to ensure that the new code is working correctly before making it the default.

## console-speed-bps

***baud-rate-bps=9600 or 19200 or 38400 or 57600 or 115200***

Sets the Auxiliary port of the radio to the specified baud rate. This setting is not saved in the radio configuration, the auxiliary port always powers up set for 9600 baud.

This command is useful to speed up the download process over the auxiliary port. Before issuing the download command, use this command to change the radio console speed to the highest baud rate supported by the PC. Then change the terminal settings to match the radio speed. Issue the download command described below and initiate the transfer at the terminal.

Examples:

```
>console-speed-bps baud-rate-bps=115200
```

## copy-file

***source=filename***

***destination=filename***

Copies the input-file into the output-file. If the memory location is not defined (flash or tmp), the command assumes the flash directory.

Examples:

```
>copy-file tmp/vip01_02 vip01_02
```

## delete-file

***filename=filename***

Deletes the specified file from RAM or Flash PROM. If the memory location is not defined (flash or tmp), the command assumes the flash directory.

Examples:

```
>delete-file filename=vip01_03
```

## directory

***format=short or full***

Lists all the files currently stored in flash PROM and RAM, their size, the sectors occupied and the MD5 checksum (full version). It also indicates which of the files is the default program. Files stored in flash PROM have the flash/ prefix. Files stored in RAM have the tmp/ prefix.

Examples:

```
>directory full
```

## download-file

***source=path/filename***

***destination=filename***

***method=inline or binary***

Downloads a program file from a PC to the *VIP 110-24*.

To download a file through the Ethernet port or across RF links you need to be running the Econsole program on a PC attached to a radio through the Ethernet port. In this case the program file must be in binary or binary zip format (with extension .bin or .bz). The *path/* in the source parameter is the PC directory where the file resides. The program file is transferred to the *VIP 110-24* and is stored in the radio memory under the name specified by the destination parameter. If the destination parameter is omitted, the file will be stored in Flash PROM with the same name as the source. The download "method" to use must be "binary" (which is the default).

Example:

**>download C:\EION\vip02-60-01.bz**

download the file vip02-60-01.bz from the PC directory C:\EION into the VIP110-24 flash/vip02-60-01

If the download is performed from a terminal connected to the Auxiliary port, the file is in ASCII format and has the extension .dwn. The download method must be "inline". The source parameter is not needed since, after issuing the command, the user must initiate the transfer of the file from the terminal.

Example:

**>download destination=vip02-60-01 method=inline**

After issuing the command initiate the file transfer using the terminal facilities..

**run**

*filename=filename*

Executes the specified file. The file is first copied into RAM and then the program is executed out of RAM. If the radio is rebooted or power cycled, the radio reverts back to the program defined as the default boot program. If the memory location is not defined (flash or tmp), the command assumes the flash directory.

Examples:

**>run vip02-60-01**

**set-default-program**

*filename=filename*

Sets the specified file as the default program to be loaded upon reboot or power cycle. Since the default program must reside in flash memory, the "flash/" prefix is assumed and is not required for the command.

Examples:

**>set-default-program vip02-60-01**

## 7.13 Miscellaneous commands

### date

The VIP 110-24 will set the internal radio date and time automatically by decoding Network Time Protocol (NTP) packets received via the Ethernet LAN or wireless RF port. The “zone” parameter specified with the “date” or “time” command will then be used to display the date/time in local time. The “zone” value is saved as part of the radio configuration.

If NTP packets are not available, the user can initialize the radio date and time with either the “date” or “time” commands. The parameters for both commands are identical, but the parameter order is different. The date command can be entered as:

```
> date 16-may-2000 10:32:06
```

#### *date=day-month-year*

Sets the date used by the radio. The day / month / year parameter may be separated by any valid separator (‘-‘ ‘/’ etc.)

#### *time=hh:mm:ss*

Sets the radio time in hours, minutes and seconds. Use colons to separate the three fields.

#### *zone=zone-code or offset*

Sets the time zone to be used by the radio to translate the NTP time to local time. It can be specified by an offset from GMT (-0800 or +0200 for example), or as a “zone-code”. The valid “zone-codes” and the respective offsets are shown below:

Zone	zone code	offset
Pacific Standard Time	PST	-0800
Pacific Daylight Time	PDT	-0700
Mountain Standard Time	MST	-0700
Mountain Daylight Time	MDT	-0600
Central Standard Time	CST	-0600
Central Daylight Time	CDT	-0500
Eastern Standard Time	EST	-0500
Eastern Daylight Time	EDT	-0400
Greenwich Mean Time	GMT	0000

### ntp-server

Using these commands the VIP can be configured to set its internal clock from NT Packets received over a wireless RF port. The VIP sets its internal clock to any NTP packet it sees, even packets not intended for that VIP IP Address.

***ntp-server***=[ip address]

NTP Server tells the VIP the IP address of an NTP Server. If NTP packets frequently pass through the VIP, it may never send out an NTP request. This parameter is automatically updated through DHCP. If the DHCP server that assigned the VIP address is configured to send out an NTP server address, that address will override the ntp server value.

***update-interval-hours***=240

If the VIP does not see a network time packet in a specified amount of time, the VIP sends out an NTP request to a specified server. The timer is reset when an NTP packet is seen. If NTP packets frequently pass through the VIP, it may never send out an NTP request.

***request-ntp***=*disable*

The disable parameter stops all NTP packet requests.

**help** [command-name]

If no command is specified, displays the complete list of commands. If a command is specified it displays the valid parameter and corresponding values for that specific command.

Examples:

**>help monitor-link**

**history**

Displays the previous commands entered.

**license**

***key***=< ASCII string >

The "license" command is used to turn ON or OFF a set of optional features or capabilities. The key is a 35-character string combination of ASCII letters, numbers, and hyphens. The key must be input with the syntax as shown in the example below, including hyphens, for the radio to accept it. The characters can be input as upper or lower case.

After entering the key you must reboot the radio for the feature, enabled by the key, to take effect.

Each key is unique for a particular radio serial number and capability, i.e. a key generated to turn ON a capability on one serial number will not work on another radio.

Example:

**>license key=02EL1-ZGZ42-G0000-00C54-81WAJ-C9BEK**

**logout**

Closes the current Econsole or telnet session.

## reboot

Resets the radio causing the software to perform a complete start up sequence. This is equivalent to power cycling the radio off and on.

## time

*time=hh:mm:ss*

*date=day-month-year*

*zone=zone-code or offset*

This command is identical to the “date” command explained above except for the order of the parameters. It allows the time and date to be entered as:

**> time 10:32:06 16-may-2000**

## version

Displays the radio model and software version.



## **8 NETWORK MANAGEMENT**

The VIP radio operates as part of a network environment with many devices. Whether operated by an Internet Service Provider (ISP) or the Information Technology (IT) department of a business, there is often a need to supervise and manage the network from a central Network Operations Center (NOC). This chapter describes the features of the VIP 110-24 that are useful for this purpose.

### **8.1 Telnet**

#### **8.1.1 General**

Telnet, which stands for Telecommunications Network, is a protocol that allows an operator to connect to a remote machine giving it commands interactively. Once a telnet session is in progress, the local machine becomes transparent to the user, it simply simulates a terminal as if there was a direct connection to the remote machine. Commands typed by the user are transmitted to the remote machine and the responses from the remote machine are displayed in the telnet simulated terminal.

#### **8.1.2 Starting a Telnet Session**

In order to start a telnet session with a VIP radio you should first change the VIP default IP address to a unique value. This is done with the *ip-configuration* command described in section 6.6. This initial configuration can be done using telnet, the RS-232 console port or the ECON program.

To connect via telnet, you must start the telnet application at the local machine and establish a connection with the IP address of the VIP. If the local machine is a PC running Windows, you can start Telnet through Hyperterminal as follows:

1. Start the Hyperterminal application (in a typical Windows installation Hyperterminal can be found from the **Start** button under Programs/Accessories/Communications...)
2. From the **File** menu choose **New Connection**.
3. In the **Name** field enter any name you wish and press the OK button. This will open the "Connect To" window.
4. In the last field, titled "**Connect using:**", select **TCP/IP (Winsock)**. The fields above will change to **Host Address:** and **Port Number:**.
5. In the **Host Address** field, type the IP address of the VIP radio, then press the OK button. New VIP radios default to an IP address of 192.168.1.100. This should be changed immediately to another address using the "ip-configuration address=xxx.xxx.xxx.xxx" command. Multiple units on the network cannot have the same IP address.
6. TCP will now attempt to connect to the specified device. If successful the radio will request a login name with the prompt **login:**
7. Type *supervisor* followed by the Enter key

The VIP will now display its prompt command and you may type any commands as described in section 7.

If after entering the *supervisor* login name, the terminal displays the message "Login Failed", this may be due to the VIP being configured to be managed from only some specific IP addresses. This is explained in the following section.

### 8.1.3 Telnet Security

The remote management capability through Telnet opens the possibility for an unauthorized user to login to any VIP accessible through the Internet. The VIP configuration can be password protected with the use of the **lock** and **unlock** commands. If further security is desired you can specify up to four source IP addresses that are authorized to initiate Telnet sessions with the VIP. When configured in this way, the VIP will reject Telnet requests from all IP addresses that are not in the authorized list.

The authorized source IP addresses for Telnet are the same addresses that are authorized to perform SNMP management. They are entered using the *snmp* command described in section 6.6 and can be viewed with the *display-configuration* command. When this list is empty, you can initiate a Telnet session from any IP address with the login name *supervisor*. When this list is not empty, Telnet sessions can only be initiated from the listed hosts. Additionally, for each host, the login name must match the string listed for the *community* field.

If you wish to use this security feature you need know the IP address of the local machine. On a PC running Windows, one way to find its IP address is to open a DOS window and issue the command:

```
>ipconfig
```

## 8.2 **SNMP**

### 8.2.1 Command Line Interface Versus SNMP

Configuration settings on the VIP 110-24 are displayed and modified using a command line interface, which can be accessed using either the RS-232 console port, the ECONSOLE program, or via a TELNET session.

In a NOC environment, there is a need for an automated monitoring system to collect on an ongoing basis information from devices in the network for three purposes:

- 1) to build an inventory of all the devices of the network
- 2) to keep track of all devices on the network and raise alarms when any device becomes unreachable (device failed, link down, etc)
- 3) to maintain statistics on traffic levels in order to implement usage-based charging, or to determine where congestion exists in the network, so that the network can be expanded to accommodate growth

Command line interfaces are not very suitable for these purposes, and the VIP 110-24 supports the Simple Network Management Protocol (SNMP) to assist in these tasks. SNMP is a simple, transaction-based (command/response) protocol, which allows a variety of third-party software products to query network devices and collect data for these purposes.

For a generic introduction to the SNMP protocol, we recommend the book "The Simple Book - An Introduction to Internet Management" by Marshall T Rose (P T R Prentice-Hall, 1994).

### 8.2.2 What is SNMP?

The SNMP protocol is described in the following documents:

- RFC1157 - Simple Network Management Protocol (SNMP) - <ftp://ftp.isi.edu/in-notes/rfc1157.txt>
- RFC1155 - Structure and identification of management information for TCP/IP-based internets - <ftp://ftp.isi.edu/in-notes/rfc1155.txt>
- RFC1213 - Management Information Base for Network Management of TCP/IP-based internets: MIB-II - <ftp://ftp.isi.edu/in-notes/rfc1213.txt>

SNMP is a specification for the interaction (*protocol*) between the *SNMP agent* embedded in a network device, and the *SNMP manager* software running on another machine in the network.

The data provided by the SNMP agent in a network device is described by a document called the MIB (Management Information Base). **MIB-II** describes the basic information provided by all devices, and additional documents describe optional extensions for components that may not exist in most devices.

Devices may also provide non-standard MIB groups. In order for a network management system to make use of these extended features, the MIB description must be obtained from the device manufacturer and loaded into the management station.

SNMP data travels in IP packets, using the UDP port 161 for the agent, so in order to use SNMP, the device must have an IP address.

### 8.2.3 Security Considerations in SNMP

SNMP was designed before the Internet grew commercial, and the original design was not secure. Later versions intended to provide security, but grew cumbersome and complex. As a result, most devices provide secure operation in a non-standard way.

The original SNMP design as embedded in the protocol, assigns network devices to named communities. Any transactions exchanged between the agent and the manager include the name of the community to which they both belong. The agent has a list of which access rights (set, get, trap) it will grant for each community of which it is a member.

In the VIP 110-24, this has been re-interpreted: The radio has a list of up to 4 management stations from which it will accept requests, and for each one - identified by its IP address - it is indicated what access rights it is granted, and which community string it must use. Requests from all other sources are ignored. Refer to the *snmp* command in section 6.6 for details on how to configure the radio for management using SNMP..

If no management stations are listed, *get*-requests with the community *public* will be accepted and responded to from any IP address.

## 8.2.4 Examples of Network Management Systems

Some of the most common network management systems are listed below. All of them provide many similar features, including network status displays showing key devices on a map, where the devices change color if they have alarms, and with provisions for activating a remote paging device if there is a problem.

### **WhatsUp Gold (Ipswitch Inc)**

<http://www.ipswitch.com/>

USD 800 (approx)

### **SNMPc (Castle Rock Computing, Inc)**

<http://www.castlerock.com/>

USD 900 to USD 2700 (approx, depending on options)

### **OpenView (Hewlett-Packard)**

<http://www.openview.hp.com/>

USD 3,000 to USD 10,000

The OpenView product line has been revamped; HP is now positioning it not as a turnkey software product, but as a custom adapted application to be bought through a value-added implementation partner.

### **Multi-Router Traffic Graphing**

<http://www.mrtg.org/>

This is a free, open-source software, capacity planning tool.

## 8.2.5 VIP 110-24 Management Information Base (MIB)

The VIP 110-24 implements only the core MIB-II. A management station will see 3 interfaces in the *interfaces group*:

1 - VINE bridge

2 - Ethernet

3 - Radio

The first of these represents the attachment of the SNMP agent to the bridged network. Only IP traffic seen by the embedded host is counted.

The ethernet device (*ifIndex=2*) represents the traffic passing through the radio's ethernet port. This is what should be tracked by MRTG.

The third device represents the wireless transceiver. It will appear as *down* if the radio does not have a working link to a neighbor (a root node must have at least one child, all other nodes must have a parent). This is useful for confirming the loss of a link. The traffic counts show all packets to and from the radio, including handshaking between adjacent radios, as well as data being relayed from this radio's children to its parent and vice versa

## 8.3 FTP

### 8.3.1 File Transfer Protocol

As part of the standard software load, the VIP 110-24 has an imbedded File Transfer Protocol (FTP) server. An FTP server allows a user to upload and download files over the air via a secure and well known format. Since the connection is established via the radio's IP address and resides in the Application layer of the Internet Protocol Suite, an FTP session can be from any FTP client, allowing remote management of the radio. The FTP protocol is defined by RFC 959. Many good sources describing the capability of FTP can be found on web sites such as: [www.faqs.org/rfcs/rfc959.html](http://www.faqs.org/rfcs/rfc959.html). Although the VIP does not contain the complete instruction set as described in RFC 959, it supports the most commonly used commands required to upload and download files.

### 8.3.2 Using FTP with the VIP 110-24

To start an FTP session, make sure the local machine has an FTP client installed. Any Windows based computer using WIN98 (or newer) as an operating system can access an FTP client at the DOS or Command Prompt. In addition to the command prompt FTP, several GUI based FTP programs are available, such as Ipswitch's WS\_FTP and Coffee Cup FTP.

Using a command line interface, send the command:

```
ftp zzz.yyy.xx.www
```

where zzz.yyy.xx.www is the IP address of the radio. The VIP FTP Server will prompt for a username and password. Use "vip" as the username with the supervisor password (default=supervisor). Once the radio is accessed, file can be downloaded or uploaded using standard FTP commands.

The VIP memory space is comprised of two directories, "flash" and "tmp". The operational code is stored in the *flash* directory. Any new software should be placed in the *flash* directory as images place in the *tmp* directory cannot be run. In addition, any software placed in the *tmp* directory is lost when the radio is re-booted.

## 8.4 Web Download

With "Web Download" you can transfer a file from a website and the VIP 110-24 will save the file to flash/ or tmp/ storage.

### 8.4.1 Web Download Syntax

```
web-download<source>[<destination>]
```

**Example:**

```
http://127.0.0.1:80/path/filename.ext
```

<source> is the address of the file you want to download. In the <source> field, provide the current IP address of the file.

Optional *<source>* information includes:

- http://
- a port. In the example, :80 is the port. (If you do not specify a port, port 80, a common default port, will be used.)

*[destination]* determines where the file you download is stored.

In the *[destination]* field, you can save information to the VIPs flash drive or the VIPs RAM drive.

- flash/filename—files stored in the flash drive are saved after a power cycle.
- tmp/filename—files stored in the RAM drive are lost after a power cycle.

The *[destination]* field is optional, however, if you do not designate a file storage location, then all web downloads are saved to tmp/webfile.

The Web Download feature is case-sensitive. To use upper case letters or file extensions in the source parameter, put the parameter in double-quotes (“”).

**Example:**

“http://127.0.01/FileName.Ext”

## 8.5 Email Alarm Client

The Email Alarm Client notifies you, by email that a critical event has occurred in your system. As well as generating an email, the critical error is saved in the event log and/or displayed on the RS-232 console.

To prevent receiving multiple emails about the same event, only enable Email Alarm Client on a Root or Repeater. To enable Email Alarm Client, the Root or Repeater must be able to access an SMTP server

The supported alarms are:

- Warm restart command entered by user
- Reboot command entered by user
- Single radio timeout
- Serial number not programmed - using random MAC address
- Command-line denied access to host
- FTP server denied access to host
- DHCP Lease expired

- A pass key has been requested to recover a lost password
- RF Drop Link
- Invalid Network ID
- Invalid Protocol Version
- Invalid MAC address
- RSSI dropped below fade margin for link

See section 7.9 Installation and Link Monitoring Commands for a full list of supported commands for the Email Alarms feature.



## **APPENDIX A – Command Summary (alphabetical)**

This appendix lists all commands in alphabetical order. The table contains the functional group of the command. Further information about the command can be found in appendix B or section 7.

<b>Command</b>	<b>Parameters</b>	<b>Functional Group</b>
antenna-alignment-aid	output node	Installation and Link monitoring (7.9)
change-password	enable-configuration enable-monitor	Configuration Management (7.4)
clear-log	region	Event Logging (7.10)
console-speed-bps	baud-rate-bps	File Utilities (7.12)
copy-file	source destination	File Utilities (7.12)
create-script	filename leaf-script	Scripts (7.11)
date	date time zone	Miscellaneous (7.13)
delete-file	filename	File Utilities (7.12)
dhcp	action	IP Management (7.7)
directory	format	File Utilities (7.12)
display-configuration	source	Configuration Management (7.4)
display-environment		Installation and Link monitoring (7.9)
display-log	region length id min-level max-level	Event Logging (7.10)
display-scout		Installation and Link monitoring (7.9)
download-file	source destination method	File Utilities (7.12)

<b>Command</b>	<b>Parameters</b>	<b>Functional Group</b>
email	alerts e-mail-address smtp-id interval	Event Logging (7.10)
ethernet	speed timeout-sec multicast-timeoout-sec	Bridge Management (7.6)
help	command	Miscellaneous (7.13)
history		Miscellaneous (7.13)
ip-configuration	address netmask gateway	IP Management (7.9)
license	key	Miscellaneous (7.13)
load-configuration	source	Configuration Management (7.4)
lock		Configuration Management (7.4)
logout		Miscellaneous (7.13)
max-event	save print	Event Logging (7.9)
max-flow-rate	transmit-kbps receive-kbps	Major Configuration Parameters (7.5)
min-flow-rate	transmit-kbps receive-kbps	Major Configuration Parameters (7.5)
monitor-environment	channel input	Installation and Link monitoring (7.9)
monitor-flow		Installation and Link monitoring (7.9)
monitor-link	node clear	Installation and Link monitoring (7.9)
node	network-id name type anchor location contact	Major Configuration Parameters (7.5)

<b>Command</b>	<b>Parameters</b>	<b>Functional Group</b>
ntp-server	ntp-server update-interval-hours request-ntp	Miscellaneous (7.13)
packet-switch	multicast-wire multicast-rf	Bridge Management (7.6)
ping	destination count size-bytes	IP Management (7.7)
polling-list	level	Bridge Management (7.6)
polling-show	source	Bridge Management (7.6)
single-node-reboot-timeout	timeout-sec	Major Configuration Parameters (7.5)
reboot		Miscellaneous (7.13)
rf-from-children	channel	Major Configuration Parameters (7.5)
rf-from-parent (rffp)	chx chx-ant speed-mbps power-dbm dpc lm	Major Configuration Parameters (7.5)
rf-nnp-1	channel power-dbm	Major Configuration Parameters (7.5)
rf-nnp-2	channel power-dbm enable	Major Configuration Parameters (7.5)
rf-to-parent (rftp)	speed-mbps power-dbm	Major Configuration Parameters (7.5)
rf-plug-n-play	status	Major Configuration Parameters (7.5)
run	filename	File Utilities (7.12)
run-script	script-file results-file	Scripts (7.11)
set-default-program	filename	File Utilities (7.12)
save-configuration (sc)	destination	Configuration Management (7.4)

<b>Command</b>	<b>Parameters</b>	<b>Functional Group</b>
show-tables	table format	Bridge Management (7.6)
snmp	authentication-traps manager community access delete	IP Management (7.7)
spectrum-analysis	input display dwell-time-ms	Installation and Link monitoring (7.9)
test-rf-link	node packet-length-bytes repeat-delay-ms	Installation and Link monitoring (7.9)
time	time date zone	Miscellaneous (7.13)
time-analysis	channel input display dwell-time-ms	Installation and Link monitoring (7.9)
unlock	enable-configuration	Configuration Management (7.4)
version		Miscellaneous (7.13)
vlan-config	switch id priority	VLAN Commands (7.8)
vlan-management	management-switch management-id	VLAN Commands (7.8)
vlan-registration-table	look-up action id ethernet-registration ethernet-tagging rf-registration rf-tagging	VLAN Commands (7.8)
web-download	<ip address> [destination]	IP Management (7.7)

## **APPENDIX B - Command Summary (functional)**

This appendix lists all commands organized in the respective functional groups. Parameters that are part of the radio configuration are identified by having an entry under the "Factory Configuration" heading. When entering a command, if a parameter that is part of the radio configuration is omitted, the value for that parameter is not modified.

For commands that are not part of the radio configuration, if a parameter is omitted, the value for that parameter defaults to the value indicated in bold.

### **Configuration Management Commands**

<b>Command</b>	<b>Parameters</b>	<b>Values</b>	<b>Factory Configuration</b>
change-password	enable-configuration	<string>	none
	enable-monitor	<string>	none
display-configuration	source	<b>current</b> main alternate factory	current
load-configuration	source	<b>main</b> alternate factory file	main
lock			
save-configuration (sc)	destination	<b>main</b> alternate file	main
unlock	enable-configuration	<string>	

## Major Configuration Parameters

Command	Parameters	Values	Factory Configuration
max-flow-rate	transmit-kbps	1..10000	10000
	receive-kbps	1..10000	10000
min-flow-rate	transmit-kbps	1..8000	10
	receive-kbps	1..8000	10
node	network-id	0..4,294,967,295	0
	name	ASCII string (11 max)	EION-serial no.
	type	root repeater leaf	repeater
	anchor	0, 1	0
	location	ASCII string (25 max)	
	contact	ASCII string (25 max)	
single-node-reboot-timeout	timeout-sec	30..3600	600
rf-from-children	channel	5..35	25
rf-from-parent	ch1	5..35	5
	ch1-ant	a-antenna b-antenna none	a-antenna
	debug	0 or 1	0
	speed-mbps	1, 2, 5.5, 11	11
	power-dbm	0..23	18
	dpc	enable	
	lm	<new link margin>	12
rf-nnp-1	channel	5..35	5
	power-dbm	0..23	18
rf-nnp-2	channel	5..35	35
	power-dbm	0..23	18
	enable	0, 1	0
rf-to-parent	speed-mbps	1, 2, 5.5, 11	11

<b>Command</b>	<b>Parameters</b>	<b>Values</b>	<b>Factory Configuration</b>
	power-dbm	0..23	18
rf-plug-n-play	status	enable disable	

**Bridge Management Commands**

<b>Command</b>	<b>Parameters</b>	<b>Values</b>	<b>Factory Configuration</b>
ethernet	speed	auto 10hdx 10fdx 100hdx off	auto
	timeout-sec	5..1800	30
	multi-cast-timeout-sec	5..3600	600
packet-switch	multicast-wire	0 or 1	0
	multicast-rf	0 or 1	0
polling-list	level	1..7	1
polling-show	source	current main factory develop	current
show-tables	table	radio-nodes ethernet-stations flow-control direct-links default	default
	format	count times	count

**Internet Protocol (IP) Management Commands**

<b>Command</b>	<b>Parameters</b>	<b>Values</b>	<b>Factory Configuration</b>
ip-configuration	address	ip address	192.168.1.100
	netmask	ip address	255.255.255.0
	gateway	ip address	
ping	destination	ip address	
	count	0..500	4
	size-bytes	32..1400	
snmp	manager	ip address	none
	community	ASCII string (9 max)	
	access	g, gs, gt, gst	
	authentication-traps	o, l	
	delete	1..4	
web-download	<source>	<ip address>:[port number]	
	[destination]	flash/filename tmp/filename	

## VLAN Management Commands

Command	Parameters	Values	Factory Configuration
vlan-config	switch	enable disable	
	id	1...4049	
	priority	0...7	
vlan-registration-table	look-up	enable disable	
	action	view add modify delete clear	
	id	1...4049	
	ethernet-registration	fixed forbidden	
	ethernet-tagging	tagged untagged	
vlan-management	management-switch	enable disable	
	management-id	1...4049	

## Installation and Link Monitoring Commands

Command	Parameters	Values	Factory Configuration
antenna-alignment-aid	output	off audio	off
	node	node-name or #node-number	
display-environment			
display-scout			
monitor-environment	channel	0..50	
	input	a-antenna b-antenna	a-antenna
monitor-flow			
monitor-link	node	node-name or #node-number	
	clear	no yes	no
spectrum-analysis	input	a-antenna b-antenna	a-antenna
	display	graph table	graph
	dwel-time-ms	1...1000 (def: <b>20</b> )	
test-rf-link	node	node-name or #node-number	
	packet-length-bytes	1...1500	1500
	repeat-delay-ms	0...3000	0
time-analysis	channel	0..50	
	input	a-antenna b-antenna	a-antenna
	display	graph table	graph
	dwel-time-ms	1, 2, 5, 10, 20, 50, 100, 200, 500	20

## Event Logging Commands

Command	Parameters	Values	Factory Configuration
clear-log	region	all-events reboot-reasons	all-events
e-mail	alerts	enable disable	
	e-mail-address	<email@somewhere.com>	
	smtp-ip-address	<w.x.y.z>	
	interval	<x>	
display-log	region	end beginning all-events reboot-reasons	end
	length	1..500	10
	id	0...200	
	min-level	0...7	0
	max-level	0...7	7
max-event	save	0..7	5
	print	0..7	3

## Scripts

Command	Parameters	Values	Factory Configuration
create-script	filename	<string>	
	leaf-script	enable disable	
run-script	script-file	<string>	
	results-file	<string>	

**File Utilities**

<b>Command</b>	<b>Parameters</b>	<b>Values</b>	<b>Factory Configuration</b>
console-speed-bps	baud-rate-bps	9600, 19200, 38400 57600, 115200	9600
copy-file	source	filename	
	destination	filename	
delete-file	filename	filename	
directory	format	short full	short
download-file	source	path/filename	
	destination	path/filename	
	method	binary inline	
run-file	filename	filename	
set-default-program	filename	filename	

## Miscellaneous Commands

Command	Parameters	Values	Factory Configuration
date	date	dd-mmm-yyyy	
	time	hh:mm:ss	
	zone	offset or code	GMT
help	command		
history			
license	key	<35 character string>	
logout			
ntp-server	ntp-server	<ip address>	
	update-interval-hours	<integer>	
	request-ntp	disable	
reboot			
time	time	hh:mm:ss	
	date	dd-mmm-yyyy	
	zone	offset or code	GMT
Version			

## **APPENDIX C - Specifications**

<b>RF Specifications</b>	
RF Frequency Band	2.400 GHz to 2.483 GHz
RF Signal Bandwidth (-20 dBc)	18 MHz
RF Channels	31 (4 non-overlapping)
Transmitter Output Power	0 to 23 dBm (programmable)
Modulation Type	direct sequence spread spectrum
Throughput (Raw/Effective)	11/8 Mbps; 5.5/4 Mbps; 2.0/1.5 Mbps
Receiver Sensitivity (10 <sup>-6</sup> BER)	-90 dBm (@ 1 Mbps) -87 dBm (@ 2 Mbps) -85 dBm (@ 5.5 Mbps) -82 dBm (@ 11 Mbps)
<b>Data Interfaces</b>	
Auxiliary Port	RS-232
Ethernet Port	10/100 BaseT (auto-negotiate)
<b>Power Requirements</b>	
Input Voltage (Outdoor Unit)	+10 to +28 Volts DC
Input Voltage (AC)	110 VAC or 220 VAC
Power Consumption	less than 5 Watts
<b>Environment</b>	
Temperature	-35 to +65 Degrees C
Enclosure	IP66
Max. Humidity	90% non-condensing
<b>Mechanical:</b>	
Dimensions	4.72" wide x 8.66" high x 2.0" deep (120mm W x 220 H x 51 D)
Weight	2.4 lbs. (1.1 kg).



## **APPENDIX D – Channel Frequency Assignment**

<b>Channel</b>	<b>Frequency (GHz)</b>	<b>Channel</b>	<b>Frequency (GHz)</b>	<b>Channel</b>	<b>Frequency (GHz)</b>
5	2.410	15	2.430	25	2.450
6	2.412	16	2.432	26	2.452
7	2.414	17	2.434	27	2.454
8	2.416	18	2.436	28	2.456
9	2.418	19	2.438	29	2.458
10	2.420	20	2.440	30	2.460
11	2.422	21	2.442	31	2.462
12	2.424	22	2.444	32	2.464
13	2.426	23	2.446	33	2.466
14	2.428	24	2.448	34	2.468
				35	2.470

---

<b>Number of Non-Overlapping Channels</b>	<b>Suggested Channel Allocation</b>	<b>Frequency Separation (MHz)</b>
3	5, 20, 35	30.0
4	5, 15, 25, 35	20.0

---







## **APPENDIX E – Interconnect cables**

The following section describes the interconnect cable pin outs for the radio. There are three basic types, the CAT5 data/power cable providing DC power and ethernet to the radio, the auxiliary RS-232 interface, and the antenna alignment audio interface. These cables can be manufactured by the user using the supplied wiring diagrams or may be purchased through EION Wireless.

### **Auxiliary RS-232 Cable (EION Part Number 6010-1404)**

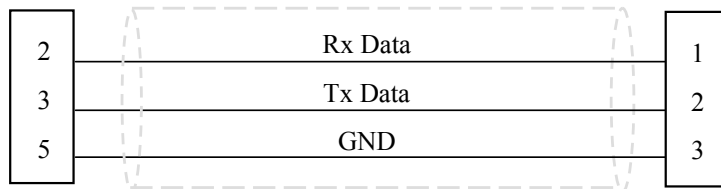

DE9-M Connector

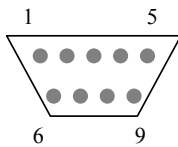

Back side  
(Looking at solder cups)

EN3C3F Connector

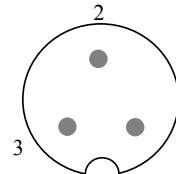

Back side  
(Looking at solder cups)

(see instructions for assembly the EN3C3F connector on the next page)

### CAT5 Power/Ethernet Cable

This cable can be ordered in three different lengths: 10 meters, 30 meters or 100 meters. The part numbers for these cables are:

10 meter	6010-1420-00
30 meter	6010-1421-00
100 meter	6010-1422-00

This cable can be ordered as Part Number C1062-005-XX where XX is the cable length. Connector kits containing the RJ-45 and ENC8F connectors are also available (Part Number SCK1062-005).

**NOTES:**

1. Colour coding conforms to EIA/TIA 568A
2. Use proper crimp tool for Item #2 connection
3. Solder the drain wire to the right bottom shield on the tab side, with the tab pointing down, of the item #2.
- Make this as unobtrusive as possible.
4. Trim and fold cable shield and drain wire as per connector manufacturer's assembly instructions for item #2.
5. Do not connect the Drain wire to item #3. Trim the drain wire and shield back to the cable sheath.
6. Insure that all eight conductors reach to end of interior channel before crimping Item #2.
7. Connect wires to item # 3 as per drawing and assembly instructions

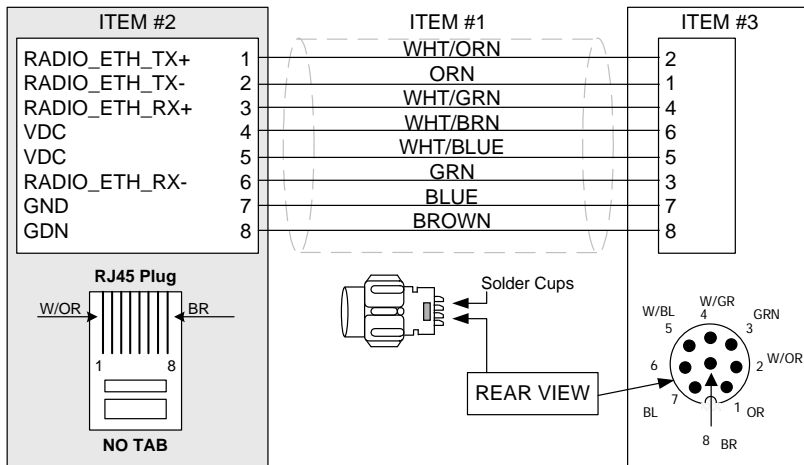

MATERIAL			
ITEM	PART NUMBER	MANUFACTURER	DESCRIPTION
1	5EXH04P24-BK-R-CMS-PV	CommScope	Cable, CAT5, Outdoor Solid Cond.
2	AT8X8SC-2224	Allen Tel	Plug Connector, 8 Cond., RJ45
3	EN3C8F	Switchcraft	8 Pin Field Connector Female

## Instructions for assembly of the Switchcraft EN3CxF Connectors

**STEP 1**

**Cord Connector:** To assemble the three-part cord connector, first feed the end of the cable through the boot, cable clamp housing, and coupling ring in that order and position as shown in the figure below. **NOTE:** The coupling ring can also be inserted onto the cord connector from the front. **In-line Connector:** Feed the end of the cable through the boot and cable clamp housing in the order and position shown.

**STEP 2**

Next, strip the cable .218" as shown and begin soldering conductors to pins, or insert contacts crimped on wire starting with contact #1 next to the "notch" and following with the remaining conductors counter-clockwise with #6 or #8 conductor in the center.

**STEP 3**

Push the cable clamp housing forward until it locks into the connector body and snap the two clamps into their compartments.

**STEP 4**

Finally, push the boot all the way forward to seat tightly onto the cable clamp housing.

Three pin connector is shown. Use same process for 8 pin.

### Auxiliary Antenna Alignment Aid Cable (EION Part Number 6050-0008)

Comment [RWK1]: Part Number not in SF

